

C.I.P.**320 Court Blanc**

TAB.

VIII

Date

91-07-29

Pays d'origine: DE

Révision

94-03-01

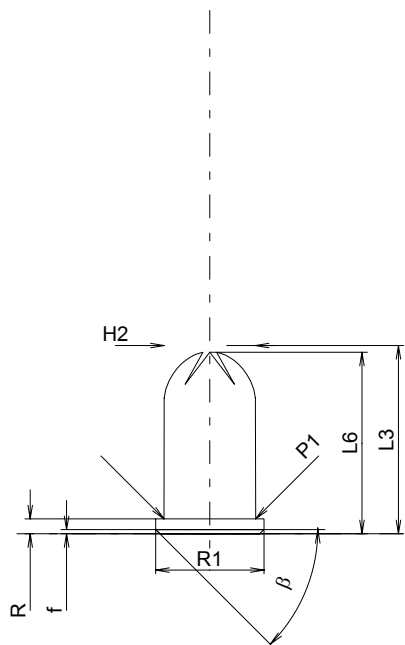
**CARTOUCHE MAXI****Longueurs**

L1	=	
L2	=	
L3 ¹⁾	=	16.60
L4	=	
L5	=	
L6 ¹⁾	=	16.00

Culot

R	=	1.32
R1	=	9.55
R3	=	
E	=	
E1	=	
e min	=	
δ	=	
f	=	0.38
β	=	45°

Chambre à poudre

P1	=	8.09
P2	=	

Cône de raccordement

α	=	
S	=	
r1 min	=	
r2	=	

Collet

H1	=	
H2 ¹⁾	=	8.05

Projectile

G1	=	
G2	=	
F	=	
L3+G	=	

Pressions (Énergies)**Méthode transducteur**

Pmax	=	250 bar
PK	=	288 bar
PE	=	325 bar
M	=	7.50

Autres indications

Fe	=	
delta L	=	

CHAMBRE MINI**Longueurs**

L1	=	
L2	=	
L3 ¹⁾	=	16.00

Cuvette

R ¹⁾	=	1.35
R1	=	9.60
R2	=	
R3	=	
r	=	

Chambre à poudre

E	=	
P1 ¹⁾	=	8.10
P2	=	

Cône de raccordement

α	=	
S	=	
r1 max	=	
r2	=	

Collet

H1	=	
H2 ¹⁾	=	8.10

Prise de rayures

G1 ^{2)*}	=	7.00
G ^{2)*}	=	16.50
α1	=	90°
h	=	0.50
s*	=	13.00
i	=	45°
w	=	1.50

Canon

F ^{2)*}	=	3.00
Z	=	3.00

Rayures

b	=	
N	=	
u	=	
Q ²⁾	=	7.07 mm ²

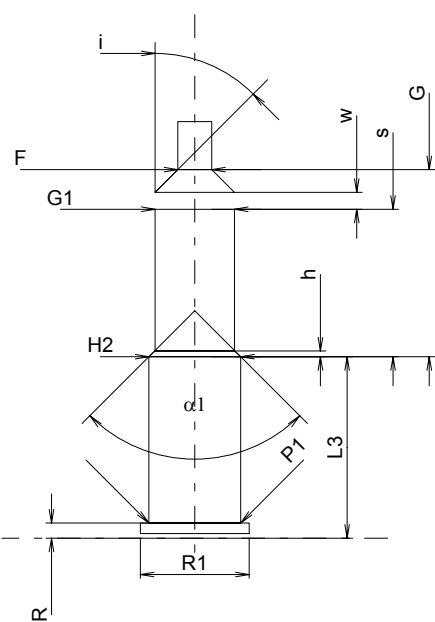

Échelle 1.5:1

Dimensions en << mm >>
Dimensions et tolérances pour les canons
d'épreuve: Voyez Annexe CR 5.

Notes: 1) A' contrôler pour la sécurité
2) Valable uniquement pour les canons d'épreuve
* Dimensions de base