

**C.I.P.****9 x 27**

TAB. VI

Date 00-10-06

Révision 02-05-15

Pays d'origine: CZ

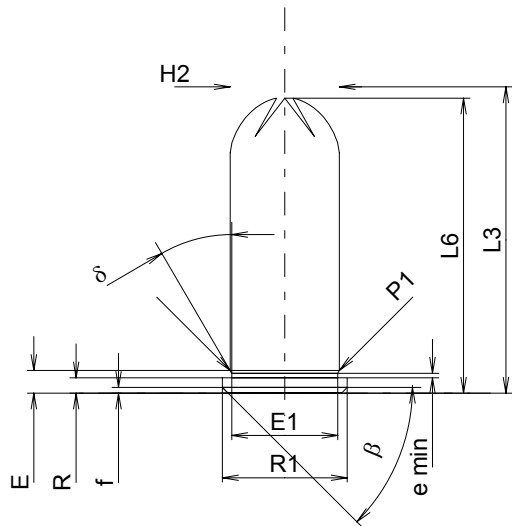
**CARTOUCHE MAXI****Longueurs**

L1	=	
L2	=	
L3 <sup>1)</sup>	=	27.00
L4	=	
L5	=	
L6	=	26.00

**Culot**

R	=	1.35
R1	=	11.00
R3	=	
E	=	1.99
E1	=	9.35
e min	=	0.40
delta	=	30°
f	=	0.50
beta	=	45°

**Chambre à poudre**

P1	=	9.63
P2	=	

**Cône de raccordement**

alpha	=	
S	=	
r1 min	=	
r2	=	

**Collet**

H1	=	
H2 <sup>1)</sup>	=	9.63

**Volumes [cm³]**

VC	=	
Va 1	=	0.40
Va 2	=	

**Pressions (Énergies)****Méthode transducteur [Va1]**

Pmax	=	3100 bar
PK	=	3565 bar
PE	=	4030 bar
M	=	

**Autres indications**

Fe	=	
delta L	=	

**CHAMBRE MINI****Longueurs**

L1	=	
L2	=	
L3 <sup>1)</sup>	=	27.00

**Cuvette**

R <sup>1)</sup>	=	1.25
R1	=	11.20
R2	=	
R3	=	
r	=	

**Chambre à poudre**

E	=	
P1	=	9.65
P2	=	

**Cône de raccordement**

alpha	=	
S	=	
r1 max	=	
r2	=	

**Collet**

H1	=	
H2	=	9.65

**Prise de rayures**

G1*	=	10.02
G	=	
alpha1	=	180°
h	=	
s	=	
i	=	
w	=	

**Canon**

F*	=	10.02
Z	=	10.02

**Volumes [cm³]**

V(ET)	=	
V(T)	=	

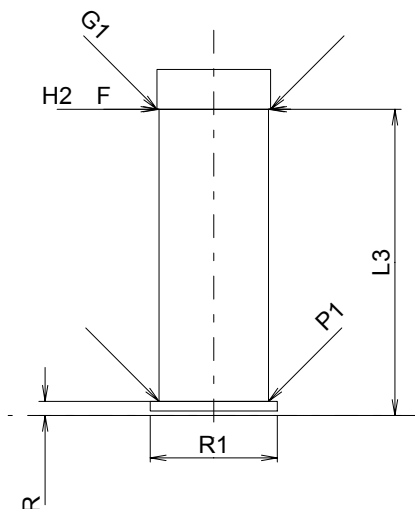

Échelle 1.5:1

Dimensions en << mm >>  
Dimensions et tolérances pour les canons  
d'épreuve: Voyez Annexe CR 3.

Notes: 1) A' contrôler pour la sécurité  
\* Dimensions de base