

C.I.P.**9mm Flobert à plombs Metal**

TAB.

V

Date

84-06-14

Révision

00-06-07

Pays d'origine: FR

CARTOUCHE MAXI**CHAMBRE MINI****Longueurs**

| | | |
|------------------|---|-------|
| L1 * | = | 10.50 |
| L2 * | = | 12.00 |
| L3 ¹⁾ | = | 45.00 |
| L4 | = | |
| L5 | = | |
| L6 | = | 45.00 |

Longueurs

| | | |
|------------------|---|-------|
| L1 | = | |
| L2 | = | |
| L3 ¹⁾ | = | 10.50 |

Culot

| | | | |
|-----------------|---|-------|-------|
| R ¹⁾ | = | 1.45 | -0.18 |
| R1 | = | 10.50 | |
| R3 | = | | |
| E | = | | |
| E1 | = | | |
| e min | = | | |
| δ | = | | |
| f | = | | |
| β | = | | |

Cuvette

| | | |
|-----------------|---|-------|
| R ¹⁾ | = | 1.45 |
| R1 | = | 10.70 |
| R2 | = | |
| R3 | = | |
| r | = | |

Chambre à poudre

| | | |
|------|---|------|
| P1 | = | 8.80 |
| P2 * | = | 8.80 |

Chambre à poudre

| | | |
|------------------|---|------|
| E | = | |
| P1 ¹⁾ | = | 8.85 |
| P2 | = | |

Cône de raccordement

| | | |
|--------|---|-----------|
| α | = | 15°11'24" |
| S | = | 43.50 |
| r1 min | = | |
| r2 | = | |

Cône de raccordement

| | | |
|--------|---|--|
| α | = | |
| S | = | |
| r1 max | = | |
| r2 | = | |

Collet

| | | |
|------------------|---|------|
| H1 * | = | 8.40 |
| H2 ¹⁾ | = | 8.35 |

Collet

| | | |
|------------------|---|------|
| H1 | = | |
| H2 ¹⁾ | = | 8.80 |

Projectile

| | | |
|--------------------|---|-------|
| G1 ¹⁾ | = | |
| G2 | = | |
| F | = | |
| L1+G ¹⁾ | = | 12.30 |

Prise de rayures

| | | |
|------|---|----------|
| G1 * | = | 8.80 |
| G * | = | 1.80 |
| α1 | = | |
| h | = | |
| s | = | |
| i | = | 6°39'15" |
| w | = | |

Pressions (Énergies)**Méthode crusher**

| | | |
|------|---|----------|
| Pmax | = | 900 bar |
| PK | = | 1035 bar |
| PE | = | 1170 bar |
| M | = | 12.50 |

Canon

| | | |
|-------------------|---|------|
| F ¹⁾ * | = | 8.38 |
| Z ¹⁾ | = | 8.38 |

Rayures

| | | |
|---|---|-----------------------|
| b | = | |
| N | = | |
| u | = | |
| Q | = | 55.15 mm ² |

Autres indications

| | | |
|------------------|---|------|
| Fe ¹⁾ | = | 0.20 |
| delta L | = | |

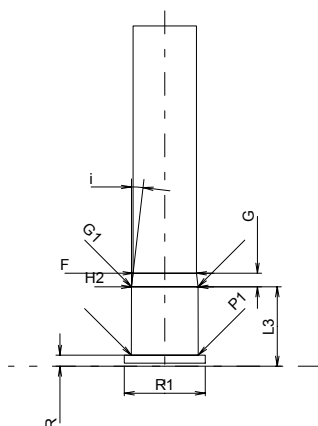
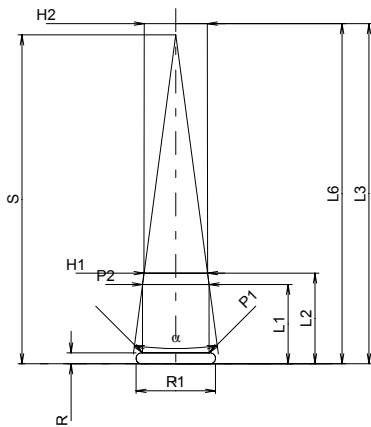

Échelle 1:1

Dimensions en << mm >>
Dimensions et tolérances pour les canons
d'épreuve: Voyez Annexe CR 2.

Notes: 1) A' contrôler pour la sécurité
* Dimensions de base