

C.I.P.**4 mm Randz. long**

TAB.

V

Date

84-06-14

Révision

00-06-07

Pays d'origine: DE

CARTOUCHE MAXI**CHAMBRE MINI****Longueurs**

L1	=	
L2	=	
L3 ¹⁾	=	8.50
L4	=	
L5	=	
L6	=	11.20

Longueurs

L1	=	
L2	=	
L3 ¹⁾	=	8.60

Culot

R ¹⁾	=	1.30	-0.18
R1	=	6.10	
R3	=		
E	=		
E1	=		
e min	=		
δ	=		
f	=		
β	=		

Cuvette

R ¹⁾	=	1.20
R1	=	6.13
R2	=	
R3	=	
r	=	

Chambre à poudre

P1	=	4.65
P2	=	

Chambre à poudre

E	=	
P1 ¹⁾	=	4.70
P2	=	

Cône de raccordement

α	=	
S	=	
r1 min	=	
r2	=	

Cône de raccordement

α	=	
S	=	
r1 max	=	
r2	=	

Collet

H1	=	
H2 ¹⁾	=	4.58

Collet

H1	=	
H2 ¹⁾	=	4.58

Projectile

G1 ¹⁾	=	4.40
G2	=	
F	=	4.05
L3+G ¹⁾	=	11.15

Prise de rayures

G1 [*]	=	4.58
G [*]	=	2.65
α1	=	
h	=	
s	=	
i	=	5°42'38"
w	=	

Pressions (Énergies)**Énergy**

E _{max}	=	30.0 Joule
E _K	=	32.1 Joule
E _E	=	33.0 Joule

Canon

F ^{1)*}	=	4.05
Z ¹⁾	=	4.30

Rayures

b	=	1.25
N	=	6
u	=	450.00
Q	=	13.83 mm ²

Autres indications

Fe ¹⁾	=	0.20
delta L	=	

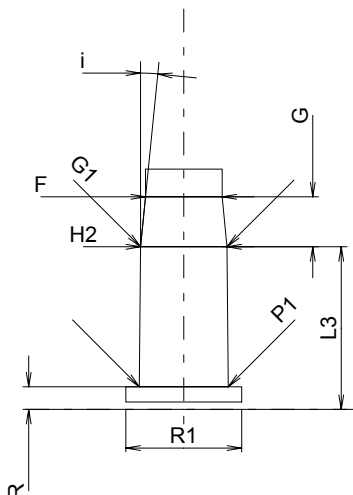
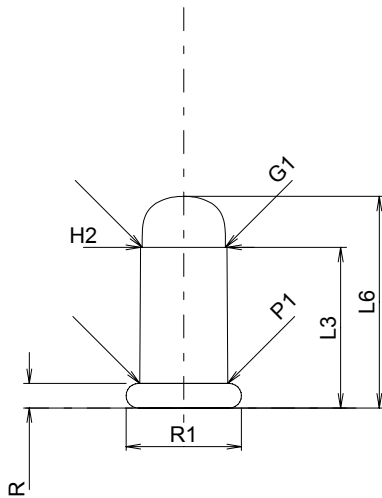

Échelle 2.5:1

Dimensions en << mm >>
Dimensions et tolérances pour les canons
d'épreuve: Voyez Annexe CR 2.

Notes: 1) A' contrôler pour la sécurité
* Dimensions de base