

C.I.P.**22 Long**

TAB.

V

Date

84-06-14

Révision

00-06-07

Pays d'origine: US

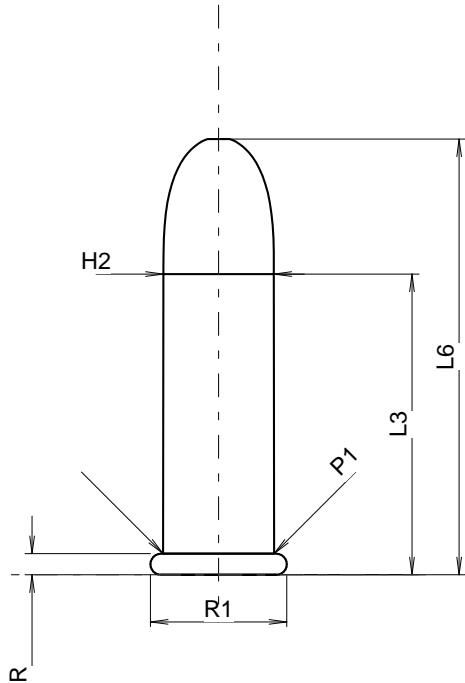
**CARTOUCHE MAXI****Longueurs**

L1	=	
L2	=	
L3 ¹⁾	=	15.57
L4	=	
L5	=	
L6	=	22.56

Culot

R ¹⁾	=	1.09	-0.18
R1	=	7.06	
R3	=		
E	=		
E1	=		
e min	=		
δ	=		
f	=		
β	=		

Chambre à poudre

P1	=	5.74
P2	=	

Cône de raccordement

α	=	
S	=	
r1 min	=	
r2	=	

Collet

H1	=	
H2 ¹⁾	=	5.72

Projectile

G1 ¹⁾	=	5.72
G2	=	
F	=	
L3+G ¹⁾	=	17.51

Pressions (Énergies)**Méthode crusher**

Pmax	=	1000 bar
PK	=	1150 bar
PE	=	1300 bar
M	=	17.37

Autres indications

Fe ¹⁾	=	0.20
delta L	=	

CHAMBRE MINI**Longueurs**

L1	=	
L2	=	
L3 ¹⁾	=	16.33

Cuvette

R ¹⁾	=	1.09
R1	=	7.32
R2	=	
R3	=	
r	=	0.25

Chambre à poudre

E	=	
P1 ¹⁾	=	5.76
P2	=	

Cône de raccordement

α	=	
S	=	
r1 max	=	
r2	=	

Collet

H1	=	
H2 ¹⁾	=	5.72

Prise de rayures

G1 *	=	5.72
G	=	1.94
α1	=	
h	=	
s	=	
i *	=	5°
w	=	

Canon

F ¹⁾ *	=	5.38
Z ¹⁾	=	5.58

Rayures

b	=	2.16
N	=	6
u	=	406.00
Q	=	24.06 mm ²

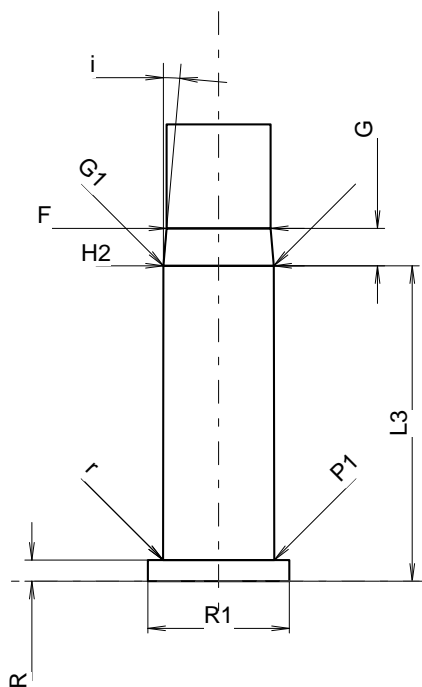

Échelle 2.56:1

Dimensions en << mm >>
Dimensions et tolérances pour les canons
d'épreuve: Voyez Annexe CR 2.

Notes: 1) A' contrôler pour la sécurité
* Dimensions de base