

C.I.P.**7,65 Parabellum**

TAB.	IV
Date	84-06-14
Révision	08-09-23

Pays d'origine: DE

Marquage alternatif: 7,65 Para, 7,65 Luger, 30 Luger

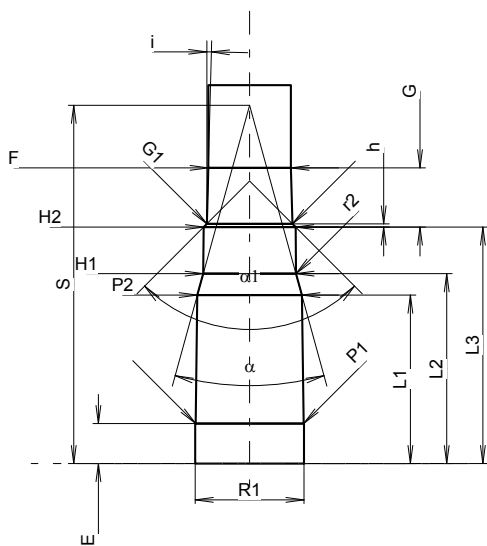
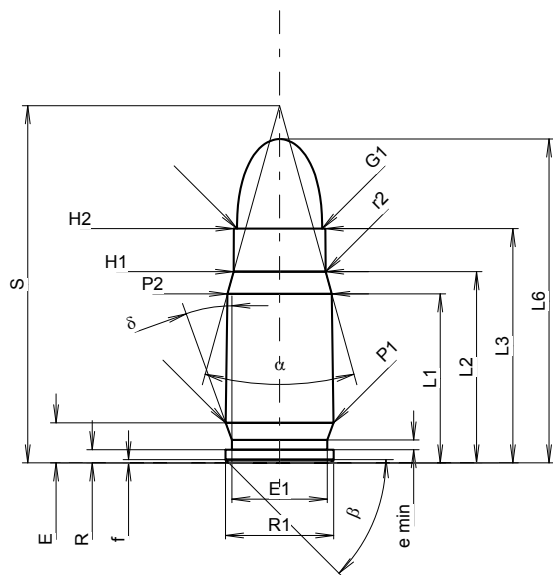

Échelle 1.44:1

Dimensions en << mm >>
Dimensions et tolérances pour les canons
d'épreuve: Voyez Annexe CR 1.

CARTOUCHE MAXI**Longueurs**

L1 1)*	=	15.58	-0.20
L2 1)*	=	17.62	-0.20
L3 1)	=	21.59	
L4	=		
L5	=		
L6	=	29.85	

Culot

R	=	1.22	
R1	=	9.98	
R3	=		
E	=	3.69	
E1	=	8.79	
e min	=	0.90	
delta	=	20°	
f	=	0.30	
beta	=	45°	

Chambre à poudre

P1	=	9.93	
P2 1)*	=	9.61	-0.20

Cône de raccordement

alpha	=	30°57'41"	
S	=	32.93	
r1 min	=		
r2	=	2.50	

Collet

H1 *	=	8.48	
H2 1)	=	8.43	

Projectile

G1 1)	=	7.85	
G2	=		
F	=		
L3+G 1)	=	27.05	

Pressions (Énergies)**Méthode transducteur**

Pmax	=	2350 bar	
PK	=	2703 bar	
PE	=	3055 bar	
M	=	12.50	

Autres indications

Fe 1)6)	=	0.20	
delta L	=		

CHAMBRE MINI**Longueurs**

L1 *	=	15.52	
L2 *	=	17.50	
L3 1)	=	21.80	

Cuvette

R	=	1.22	
R1	=	10.03	
R2	=		
R3	=		
r	=		

Chambre à poudre

E	=	3.69	
P1 1)	=	9.96	
P2 *	=	9.64	

Cône de raccordement

alpha 1)	=	30°46'45"	
S	=	33.03	
r1 max	=		
r2	=	2.50	

Collet

H1 *	=	8.55	
H2 1)	=	8.48	

Prise de rayures

G1 1)*	=	7.90	
G 1)*	=	5.46	
alpha1	=	90°	
h *	=	0.29	
s	=		
i 1)	=	1°33'03"	
w	=		

Canon

F 1)*	=	7.62	
Z 1)	=	7.83	

Rayures

b	=	3.05	
N	=	4	
u	=	275.00	
Q	=	46.92	mm ²

Notes: 1) A' contrôler pour la sécurité
6) Feuillure sur la bouche
* Dimensions de base