

**C.I.P.****45 HP**

TAB. IV

Date 84-11-16

Pays d'origine: AT

Révision 00-06-07

**CARTOUCHE MAXI****CHAMBRE MINI****Longueurs**

L1	=		
L2	=		
L3 <sup>1)</sup>	=	21.80	-0.25
L4	=		
L5	=		
L6	=	31.40	

**Longueurs**

L1	=	
L2	=	
L3 <sup>1)</sup>	=	21.81

**Culot**

R	=	1.24
R1	=	12.05
R3	=	
E	=	4.11
E1	=	10.16
e min	=	0.89
$\delta$	=	26°
f	=	0.44
$\beta$	=	45°

**Cuvette**

R	=	
R1	=	12.22
R2	=	
R3	=	
r	=	

**Chambre à poudre**

P1	=	12.09
P2	=	

**Chambre à poudre**

E	=	5.00
P1 <sup>1)</sup>	=	12.18
P2	=	

**Cône de raccordement**

$\alpha$	=	
S	=	
r1 min	=	
r2	=	

**Cône de raccordement**

$\alpha$	=	
S	=	
r1 max	=	
r2	=	

**Collet**

H1	=	
H2 <sup>1)</sup>	=	12.01

**Collet**

H1	=	
H2 <sup>1)</sup>	=	12.04

**Projectile**

G1 <sup>1)</sup>	=	11.48
G2	=	
F	=	
L3+G <sup>1)</sup>	=	24.57

**Prise de rayures**

G1 <sup>1)*</sup>	=	11.48
G <sup>1)*</sup>	=	2.77
$\alpha 1$	=	180°
h	=	
s	=	
i <sup>1)</sup>	=	2°35'02"
w	=	

**Pressions (Énergies)****Méthode transducteur**

Pmax	=	1300 bar
PK	=	1495 bar
PE	=	1690 bar
M	=	12.50

**Canon**

F <sup>1)*</sup>	=	11.23
Z <sup>1)</sup>	=	11.43

**Rayures**

b	=	3.73
N	=	6
u	=	406.00
Q	=	101.33 mm <sup>2</sup>

**Autres indications**

Fe <sup>1)</sup>	=	0.30
delta L	=	

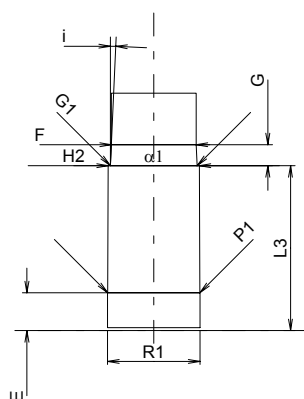
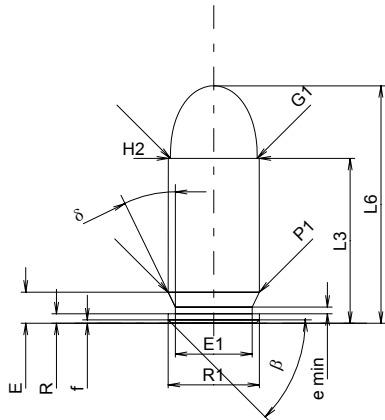

Échelle 1:1

Dimensions en << mm >>  
Dimensions et tolérances pour les canons  
d'épreuve: Voyez Annexe CR 1.

Notes: 1) A' contrôler pour la sécurité  
\* Dimensions de base