

C.I.P.**44 S&W Russian**

TAB. IV

Date 84-06-14

Pays d'origine: US

Révision 00-06-07

CARTOUCHE MAXI**CHAMBRE MINI****Longueurs**

L1	=	
L2	=	
L3 ¹⁾	=	24.64
L4	=	
L5	=	
L6	=	36.32

Longueurs

L1	=	
L2	=	
L3 ¹⁾	=	25.15

Culot

R ¹⁾	=	1.52	-0.25
R1	=	13.08	
R3	=		
E	=		
E1	=		
e min	=		
δ	=		
f	=	0.50	
β	=	35°	

Cuvette

R ¹⁾	=	1.52
R1	=	13.16
R2	=	
R3	=	
r	=	

Chambre à poudre

P1	=	11.61
P2	=	

Chambre à poudre

E	=	
P1 ¹⁾	=	11.62
P2	=	

Cône de raccordement

α	=	
S	=	
r1 min	=	
r2	=	

Cône de raccordement

α	=	
S	=	
r1 max	=	
r2	=	

Collet

H1	=	
H2 ¹⁾	=	11.59

Collet

H1	=	
H2 ¹⁾	=	11.61

Projectile

G1 ¹⁾	=	10.98
G2	=	
F	=	
L3+G ¹⁾	=	38.23

Prise de rayures

G1 ^{1)*}	=	10.97
G ¹⁾	=	13.59
α1 [*]	=	20°24'
h	=	1.78
s	=	11.42
i ^{1)*}	=	5°
w	=	

Pressions (Énergies)**Méthode transducteur**

Pmax	=	1000 bar
PK	=	1150 bar
PE	=	1300 bar
M	=	12.50

Canon

F ^{1)*}	=	10.59
Z ¹⁾	=	10.90

Rayures

b	=	3.26
N	=	5
u	=	508.00
Q	=	90.65 mm ²

Autres indications

Fe ¹⁾	=	0.25
delta L	=	

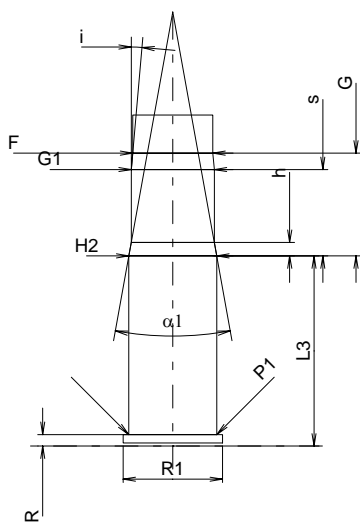
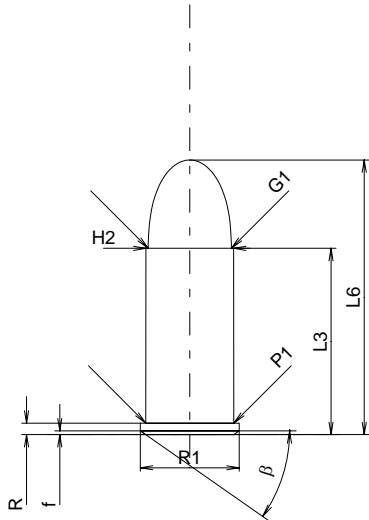

Échelle 1:1

Dimensions en << mm >>
Dimensions et tolérances pour les canons
d'épreuve: Voyez Annexe CR 1.

Notes: 1) A' contrôler pour la sécurité
* Dimensions de base