

**C.I.P.****38 Special**

TAB. IV

Date 84-06-14

Pays d'origine: US

Révision 00-06-07

**CARTOUCHE MAXI****CHAMBRE MINI****Longueurs**

L1	=	
L2	=	
L3 <sup>1)</sup>	=	29.34
L4	=	
L5	=	
L6	=	39.37

**Longueurs**

L1	=	
L2	=	
L3 <sup>1)</sup>	=	29.54

**Culot**

R <sup>1)</sup>	=	1.50	-0.25
R1	=	11.18	
R3	=		
E	=		
E1	=		
e min	=		
δ	=		
f	=	0.38	
β	=	35°	

**Cuvette**

R <sup>1)</sup>	=	1.50
R1	=	11.28
R2	=	
R3	=	
r	=	

**Chambre à poudre**

P1	=	9.63
P2	=	

**Chambre à poudre**

E	=	
P1 <sup>1)</sup>	=	9.68
P2	=	

**Cône de raccordement**

α	=	
S	=	
r1 min	=	
r2	=	

**Cône de raccordement**

α	=	
S	=	
r1 max	=	
r2	=	

**Collet**

H1	=	
H2 <sup>1)</sup>	=	9.63

**Collet**

H1	=	
H2 <sup>1)</sup>	=	9.65

**Projectile**

G1 <sup>1)</sup>	=	9.12
G2	=	
F	=	
L3+G <sup>1)</sup>	=	43.06

**Prise de rayures**

G1 <sup>1)*</sup>	=	9.09
G <sup>1)</sup>	=	13.72
α1 <sup>*</sup>	=	13°
h	=	2.46
s <sup>*</sup>	=	11.91
i <sup>1)*</sup>	=	4°45'
w	=	

**Pressions (Énergies)****Méthode transducteur**

Pmax	=	1500 bar
PK	=	1725 bar
PE	=	1950 bar
M	=	12.50

**Canon**

F <sup>1)*</sup>	=	8.79
Z <sup>1)</sup>	=	9.02

**Rayures**

b	=	2.67
N	=	6
u	=	476.00
Q	=	62.55 mm <sup>2</sup>

**Autres indications**

Fe <sup>1)</sup>	=	0.25
delta L	=	

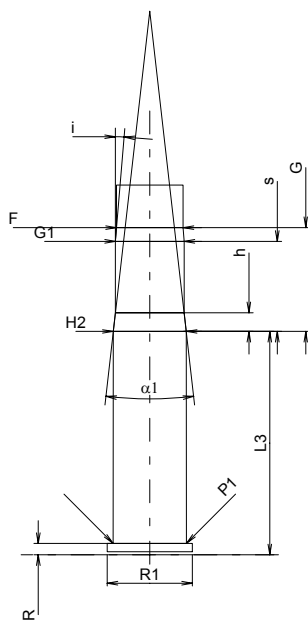
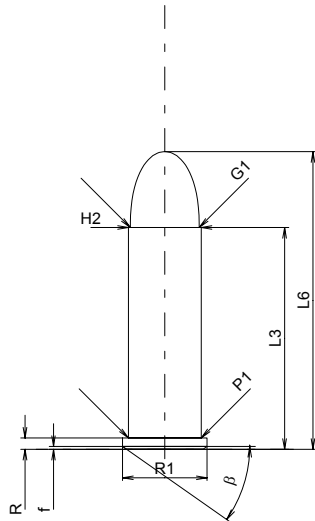

Échelle 1:1

Dimensions en << mm >>  
Dimensions et tolérances pour les canons  
d'épreuve: Voyez Annexe CR 1.

Notes: 1) A' contrôler pour la sécurité  
\* Dimensions de base