

C.I.P.**300 H&H Mag.**

TAB. III

Date 84-06-14

Révision 11-05-25

Pays d'origine: GB

Marquage alternatif: 30 Super Belt. Riml. H&H, 300 H&H Belt. Riml. N.E.

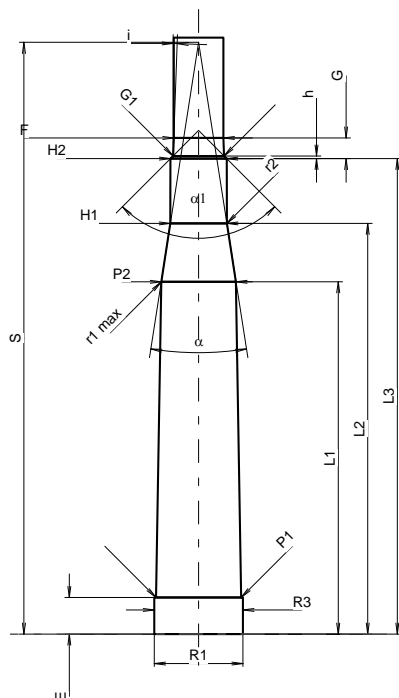
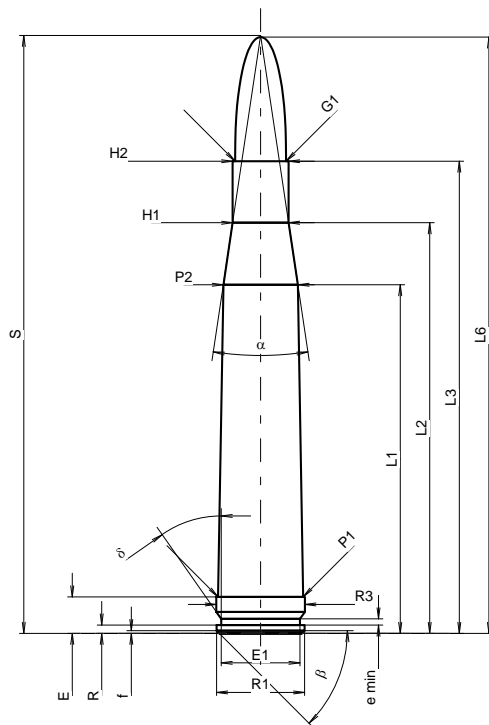

Échelle 1:1.16

Dimensions en << mm >>
Dimensions et tolérances pour les canons
d'épreuve: Voyez Annexe CR 1.

CARTOUCHE MAXI**Longueurs**

L1 *	=	53.46
L2 *	=	62.96
L3 ¹⁾	=	72.39
L4	=	
L5	=	
L6	=	91.44

Culot

R	=	1.27
R1	=	13.51
R3	=	13.56
E ¹⁾	=	5.59
E1	=	12.07
e min	=	0.94
delta	=	35°
f	=	0.41
beta	=	45°

Chambre à poudre

P1	=	13.03
P2 *	=	11.43

Cône de raccordement

alpha	=	17°00'9"
S	=	91.69
r1 min	=	
r2	=	

Collet

H1 *	=	8.59
H2 ¹⁾	=	8.59

Projectile

G1 ¹⁾	=	7.82
G2	=	
F	=	
L3+G ¹⁾	=	75.56

Pressions (Énergies)**Méthode transducteur**

Pmax	=	4300 bar
PK	=	4945 bar
PE	=	5375 bar
M	=	25.00
EE	=	4725 Joule

Autres indications

Fe ¹⁾⁵⁾	=	0.10
delta L	=	

CHAMBRE MINI**Longueurs**

L1 *	=	54.01
L2 *	=	62.96
L3 ¹⁾	=	72.90

Cuvette

R	=	
R1	=	13.59
R2	=	
R3	=	13.59
r	=	

Chambre à poudre

E ¹⁾	=	5.59
P1 ¹⁾	=	13.06
P2 *	=	11.45

Cône de raccordement

alpha	=	17°43'05"
S	=	90.74
r1 max	=	1.27
r2	=	2.54

Collet

H1 *	=	8.66
H2 ¹⁾	=	8.62

Prise de rayures

G1 ¹⁾ *	=	7.82
G ¹⁾ *	=	3.17
alpha1	=	90°
h *	=	0.40
s	=	
i ¹⁾	=	2°03'59"
w	=	

Canon

F ¹⁾ *	=	7.62
Z ¹⁾	=	7.82

Rayures

b	=	2.72
N	=	6
u	=	254.00
Q	=	47.27 mm ²

Notes: 1) A' contrôler pour la sécurité
5) Feuillure sur la culot magnum
* Dimensions de base