

**C.I.P.****8 x 75 RS**

TAB.

II

Date

84-06-14

Révision

02-05-15

Pays d'origine: DE

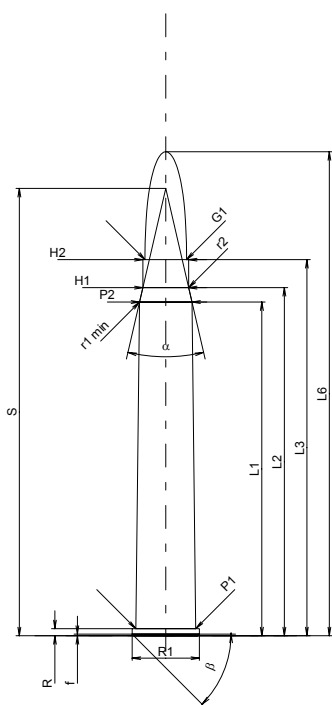
**CARTOUCHE MAXI****Longueurs**

L1 *	=	66.20
L2 *	=	69.06
L3 <sup>1)</sup>	=	74.60
L4	=	
L5	=	
L6	=	96.00

**Culot**

R <sup>1)</sup>	=	1.40	-0.25
R1	=	13.35	
R3	=		
E	=		
E1	=		
e min	=		
delta	=		
f	=	0.30	
beta	=	45°	

**Chambre à poudre**

P1	=	11.90
P2 *	=	10.40

**Cône de raccordement**

alpha	=	26°
S	=	88.72
r1 min	=	0.50
r2	=	0.50

**Collet**

H1 *	=	9.08
H2 <sup>1)</sup>	=	9.08

**Projectile**

G1 <sup>1)</sup>	=	8.22
G2	=	
F	=	
L3+G <sup>1)</sup>	=	108.60

**Pressions (Énergies)****Méthode transducteur**

Pmax	=	3800 bar
PK	=	4370 bar
PE	=	4750 bar
M	=	25.00
EE	=	4790 Joule

**Autres indications**

Fe <sup>1)</sup>	=	0.15
delta L	=	

**CHAMBRE MINI****Longueurs**

L1 *	=	66.20
L2 *	=	69.06
L3 <sup>1)</sup>	=	75.00

**Cuvette**

R <sup>1)</sup>	=	1.40
R1	=	13.40
R2	=	
R3	=	
r	=	

**Chambre à poudre**

E	=	
P1 <sup>1)</sup>	=	11.93
P2 *	=	10.43

**Cône de raccordement**

alpha	=	26°
S	=	88.79
r1 max	=	0.50
r2	=	0.50

**Collet**

H1 *	=	9.11
H2 <sup>1)</sup>	=	9.10

**Prise de rayures**

G1 <sup>1)</sup> *	=	8.23
G <sup>1)</sup> *	=	34.00
alpha1	=	180°
h	=	
s	=	
i <sup>1)</sup>	=	0°17'11"
w	=	

**Canon**

F <sup>1)</sup> *	=	7.89
Z <sup>1)</sup>	=	8.20

**Rayures**

b	=	4.40
N	=	4
u	=	240.00
Q	=	51.78 mm <sup>2</sup>

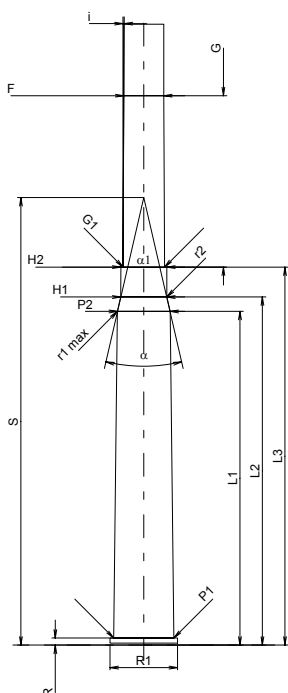

Échelle 1:1.5

Dimensions en << mm >>  
Dimensions et tolérances pour les canons  
d'épreuve: Voyez Annexe CR 1.

Notes: 1) A' contrôler pour la sécurité  
\* Dimensions de base