

**C.I.P.****8 x 60 RS**

TAB.

II

Date

84-06-14

Pays d'origine: DE

Révision

02-05-15

**CARTOUCHE MAXI****CHAMBRE MINI****Longueurs**

L1 <sup>*</sup>	=	48.22
L2 <sup>*</sup>	=	50.92
L3 <sup>1)</sup>	=	60.00
L4	=	
L5	=	
L6	=	83.60

**Longueurs**

L1 <sup>*</sup>	=	48.22
L2 <sup>*</sup>	=	50.92
L3 <sup>1)</sup>	=	60.30

**Culot**

R <sup>1)</sup>	=	1.40	-0.25
R1	=	13.40	
R3	=		
E	=		
E1	=		
e min	=		
δ	=		
f	=	0.30	
β	=	45°	

**Cuvette**

R <sup>1)</sup>	=	1.40
R1	=	13.45
R2	=	
R3	=	
r	=	

**Chambre à poudre**

P1	=	12.03
P2 <sup>*</sup>	=	10.95

**Chambre à poudre**

E	=	
P1 <sup>1)</sup>	=	12.06
P2 <sup>*</sup>	=	10.98

**Cône de raccordement**

α	=	38°12'06"
S	=	64.03
r1 min	=	0.50
r2	=	0.50

**Cône de raccordement**

α	=	38°12'07"
S	=	64.07
r1 max	=	0.50
r2	=	0.50

**Collet**

H1 <sup>*</sup>	=	9.08
H2 <sup>1)</sup>	=	9.08

**Collet**

H1 <sup>*</sup>	=	9.11
H2 <sup>1)</sup>	=	9.10

**Projectile**

G1 <sup>1)</sup>	=	8.22
G2	=	
F	=	
L3+G <sup>1)</sup>	=	94.00

**Prise de rayures**

G1 <sup>1)*</sup>	=	8.23
G <sup>1)*</sup>	=	34.00
α1	=	180°
h	=	
s	=	
i <sup>1)</sup>	=	0°17'11"
w	=	

**Pressions (Énergies)****Méthode transducteur**

Pmax	=	3400 bar
PK	=	3910 bar
PE	=	4250 bar
M	=	25.00
EE	=	4120 Joule

**Canon**

F <sup>1)*</sup>	=	7.89
Z <sup>1)</sup>	=	8.20

**Rayures**

b	=	4.40
N	=	4
u	=	240.00
Q	=	51.78 mm <sup>2</sup>

**Autres indications**

Fe <sup>1)</sup>	=	0.15
delta L	=	

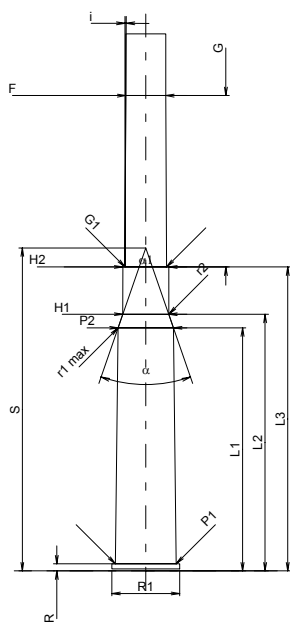
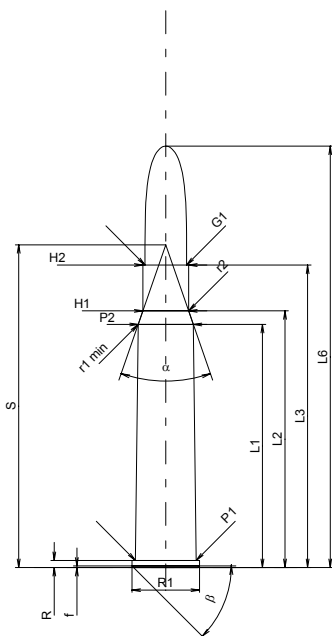

Échelle 1:1.5

Dimensions en << mm >>  
Dimensions et tolérances pour les canons  
d'épreuve: Voyez Annexe CR 1.

Notes: 1) A' contrôler pour la sécurité  
\* Dimensions de base