

**C.I.P.****7 x 72 R**

TAB. II

Date 84-06-14

Pays d'origine: DE

Révision 02-05-15

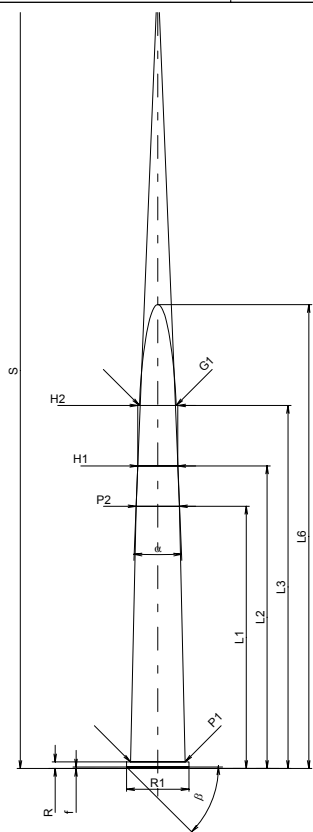
**CARTOUCHE MAXI****Longueurs**

L1 <sup>*</sup>	=	52.00
L2 <sup>*</sup>	=	60.00
L3 <sup>1)</sup>	=	72.00
L4	=	
L5	=	
L6	=	92.00

**Culot**

R <sup>1)</sup>	=	1.30	-0.25
R1	=	12.35	
R3	=		
E	=		
E1	=		
e min	=		
delta	=		
f	=	0.30	
beta	=	45°	

**Chambre à poudre**

P1	=	10.85
P2 <sup>*</sup>	=	8.60

**Cône de raccordement**

alpha	=	4°39'10"
S	=	157.85
r1 min	=	
r2	=	

**Collet**

H1 <sup>*</sup>	=	7.95
H2 <sup>1)</sup>	=	7.92

**Projectile**

G1 <sup>1)</sup>	=	7.25
G2	=	
F	=	
L3+G <sup>1)</sup>	=	91.20

**Pressions (Énergies)****Méthode transducteur**

Pmax	=	2800 bar
PK	=	3220 bar
PE	=	3500 bar
M	=	25.00
EE	=	2890 Joule

**Autres indications**

Fe <sup>1)</sup>	=	0.15
delta L	=	

**CHAMBRE MINI****Longueurs**

L1 <sup>*</sup>	=	52.00
L2 <sup>*</sup>	=	60.00
L3 <sup>1)</sup>	=	72.30

**Cuvette**

R <sup>1)</sup>	=	1.30
R1	=	12.40
R2	=	
R3	=	
r	=	

**Chambre à poudre**

E	=	
P1 <sup>1)</sup>	=	10.88
P2 <sup>*</sup>	=	8.63

**Cône de raccordement**

alpha	=	4°09'07"
S	=	171.03
r1 max	=	
r2	=	

**Collet**

H1 <sup>*</sup>	=	8.05
H2 <sup>1)</sup>	=	8.04

**Prise de rayures**

G1 <sup>1)</sup> *	=	7.29
G <sup>1)</sup> *	=	19.20
alpha1	=	90°
h <sup>*</sup>	=	0.38
s <sup>1)</sup>	=	
i	=	0°28'18"
w	=	

**Canon**

F <sup>1)</sup> *	=	6.98
Z <sup>1)</sup>	=	7.24

**Rayures**

b	=	3.90
N	=	4
u	=	220.00
Q	=	40.41 mm <sup>2</sup>

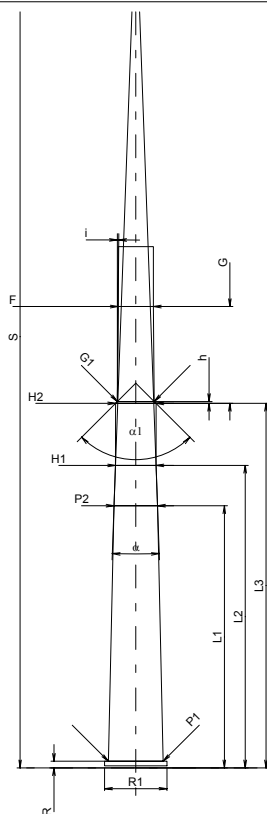

Échelle 1:1.5

Dimensions en << mm >>  
Dimensions et tolérances pour les canons  
d'épreuve: Voyez Annexe CR 1.

Notes: 1) A' contrôler pour la sécurité  
\* Dimensions de base