

**C.I.P.****6,5 x 57 R**

TAB. II

Date 84-06-14

Pays d'origine: DE

Révision 02-05-15

**CARTOUCHE MAXI****CHAMBRE MINI****Longueurs**

L1 *	=	44.50
L2 *	=	49.30
L3 <sup>1)</sup>	=	56.70
L4	=	
L5	=	
L6	=	82.00

**Longueurs**

L1 *	=	44.50
L2 *	=	49.30
L3 <sup>1)</sup>	=	57.00

**Culot**

R <sup>1)</sup>	=	1.40	-0.25
R1	=	13.32	
R3	=		
E	=		
E1	=		
e min	=		
δ	=		
f	=	0.30	
β	=	45°	

**Cuvette**

R <sup>1)</sup>	=	1.40
R1	=	13.37
R2	=	
R3	=	
r	=	

**Chambre à poudre**

P1	=	11.92
P2 *	=	10.94

**Chambre à poudre**

E	=	
P1 <sup>1)</sup>	=	11.95
P2 *	=	10.97

**Cône de raccordement**

α	=	37°50'02"
S	=	60.46
r1 min	=	0.50
r2	=	0.50

**Cône de raccordement**

α	=	37°50'02"
S	=	60.50
r1 max	=	0.50
r2	=	0.50

**Collet**

H1 *	=	7.65
H2 <sup>1)</sup>	=	7.65

**Collet**

H1 *	=	7.68
H2 <sup>1)</sup>	=	7.67

**Projectile**

G1 <sup>1)</sup>	=	6.70
G2	=	
F	=	
L3+G <sup>1)</sup>	=	86.70

**Prise de rayures**

G1 <sup>1)</sup> *	=	6.75
G <sup>1)</sup> *	=	30.00
α1	=	90°
h *	=	0.46
s	=	
i <sup>1)</sup>	=	0°17'11"
w	=	

**Pressions (Énergies)****Méthode transducteur**

Pmax	=	3300 bar
PK	=	3795 bar
PE	=	4125 bar
M	=	25.00
EE	=	3055 Joule

**Canon**

F <sup>1)</sup> *	=	6.45
Z <sup>1)</sup>	=	6.70

**Rayures**

b	=	3.50
N	=	4
u	=	200.00
Q	=	34.52 mm <sup>2</sup>

**Autres indications**

Fe <sup>1)</sup>	=	0.15
delta L	=	

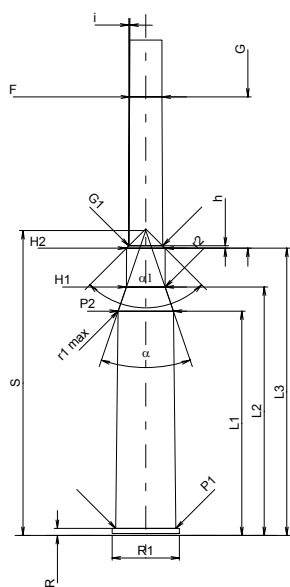
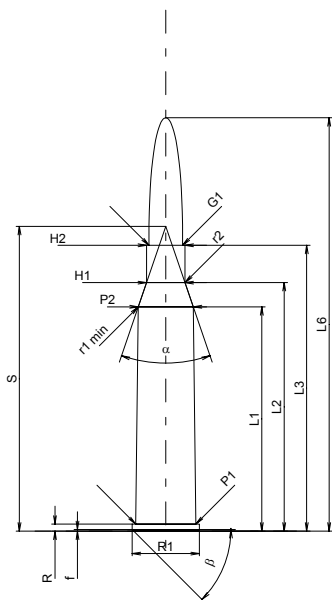

Échelle 1:1.5

Dimensions en << mm >>  
Dimensions et tolérances pour les canons  
d'épreuve: Voyez Annexe CR 1.

Notes: 1) A' contrôler pour la sécurité  
\* Dimensions de base