

**C.I.P.****577 Sld. Snider**

TAB. II

Date 84-06-14

Pays d'origine: GB

Révision 02-05-15

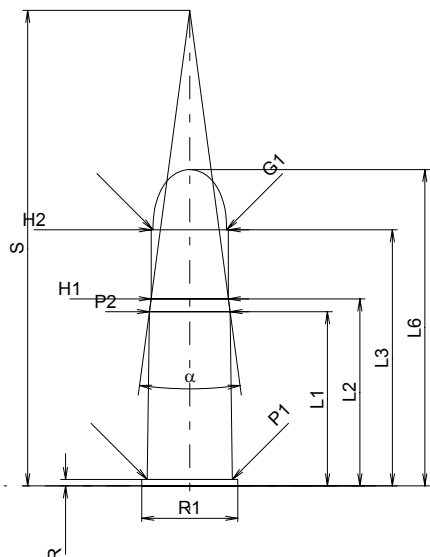
**CARTOUCHE MAXI****Longueurs**

L1 <sup>*</sup>	=	34.57
L2 <sup>*</sup>	=	37.11
L3 <sup>1)</sup>	=	50.80
L4	=	
L5	=	
L6	=	62.74

**Colot**

R <sup>1)</sup>	=	1.27	-0.25
R1	=	19.05	
R3	=		
E	=		
E1	=		
e min	=		
delta	=		
f	=		
beta	=		

**Chambre à poudre**

P1	=	16.89
P2 <sup>*</sup>	=	16.00

**Cône de raccordement**

alpha	=	15°14'53"
S	=	94.33
r1 min	=	
r2	=	

**Collet**

H1 <sup>*</sup>	=	15.32
H2 <sup>1)</sup>	=	15.32

**Projectile**

G1 <sup>1)</sup>	=	14.58
G2	=	
F	=	
L3+G <sup>1)</sup>	=	58.23

**Pressions (Énergies)****Méthode transducteur**

Pmax	=	1500 bar
PK	=	1725 bar
PE	=	1875 bar
M	=	25.00
EE	=	2290 Joule

**Autres indications**

Fe <sup>1)</sup>	=	0.15
delta L	=	

**CHAMBRE MINI****Longueurs**

L1 <sup>*</sup>	=	34.59
L2 <sup>*</sup>	=	37.13
L3 <sup>1)</sup>	=	51.05

**Cuvette**

R <sup>1)</sup>	=	1.30
R1	=	19.30
R2	=	
R3	=	
r	=	

**Chambre à poudre**

E	=	
P1 <sup>1)</sup>	=	16.92
P2 <sup>*</sup>	=	16.03

**Cône de raccordement**

alpha	=	15°28'12"
S	=	93.60
r1 max	=	
r2	=	

**Collet**

H1 <sup>*</sup>	=	15.34
H2 <sup>1)</sup>	=	15.34

**Prise de rayures**

G1 <sup>1)</sup> *	=	14.60
G <sup>1)</sup> *	=	7.43
alpha1	=	90°
h <sup>*</sup>	=	0.37
s	=	
i <sup>1)</sup>	=	1°30'02"
w	=	

**Canon**

F <sup>1)</sup> *	=	14.23
Z <sup>1)</sup>	=	14.58

**Rayures**

b	=	
N	=	
u	=	508.00
Q	=	159.04 mm <sup>2</sup>

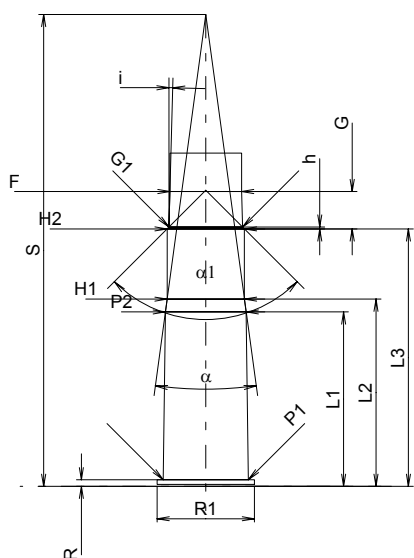

Échelle 1:1.5

Dimensions en << mm >>  
Dimensions et tolérances pour les canons  
d'épreuve: Voyez Annexe CR 1.

Notes: 1) A' contrôler pour la sécurité  
\* Dimensions de base