

**C.I.P.****35 Win. SL**

TAB. II

Date 84-06-14

Pays d'origine: US

Révision 02-05-15

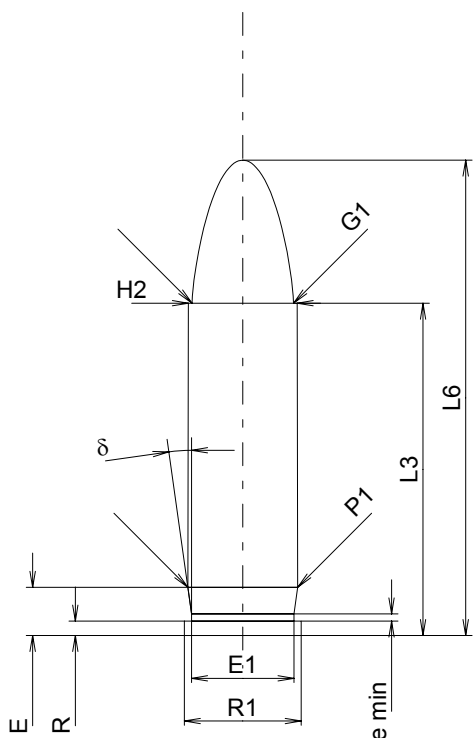
**CARTOUCHE MAXI****Longueurs**

L1	=	
L2	=	
L3 <sup>1)</sup>	=	29.31
L4	=	
L5	=	
L6	=	41.91

**Colot**

R <sup>1)</sup>	=	1.27	-0.25
R1	=	10.29	
R3	=		
E	=	4.26	
E1	=	9.02	
e min	=	0.64	
delta	=	8°	
f	=		
beta	=		

**Chambre à poudre**

P1	=	9.68
P2	=	

**Cône de raccordement**

alpha	=	
S	=	
r1 min	=	
r2	=	

**Collet**

H1	=	
H2 <sup>1)</sup>	=	9.58

**Projectile**

G1 <sup>1)</sup>	=	8.95
G2	=	
F	=	
L3+G <sup>1)</sup>	=	38.82

**Pressions (Énergies)****Méthode transducteur**

Pmax	=	2400 bar
PK	=	2760 bar
PE	=	3000 bar
M	=	17.50
EE	=	1150 Joule

**Autres indications**

Fe <sup>1)</sup>	=	0.15
delta L	=	

**CHAMBRE MINI****Longueurs**

L1	=	
L2	=	
L3 <sup>1)</sup>	=	29.81

**Cuvette**

R <sup>1)</sup>	=	1.27
R1	=	11.30
R2	=	
R3	=	
r	=	

**Chambre à poudre**

E	=	
P1 <sup>1)</sup>	=	9.77
P2	=	

**Cône de raccordement**

alpha	=	
S	=	
r1 max	=	
r2	=	

**Collet**

H1	=	
H2 <sup>1)</sup>	=	9.62

**Prise de rayures**

G1 <sup>1)*</sup>	=	8.95
G <sup>1)</sup>	=	9.51
alpha <sup>1)</sup>	=	30°
h	=	1.25
s	=	
i <sup>1)*</sup>	=	0°39'31"
w	=	

**Canon**

F <sup>1)*</sup>	=	8.76
Z <sup>1)</sup>	=	8.92

**Rayures**

b	=	2.75
N	=	6
u	=	406.00
Q	=	61.61 mm <sup>2</sup>

Échelle 1.5:1

Dimensions en << mm >>  
Dimensions et tolérances pour les canons  
d'épreuve: Voyez Annexe CR 1.

Notes: 1) A' contrôler pour la sécurité  
\* Dimensions de base