

**C.I.P.****219 Zipper**

Pays d'origine: US

TAB. II

Date 84-06-14

Révision 02-05-15

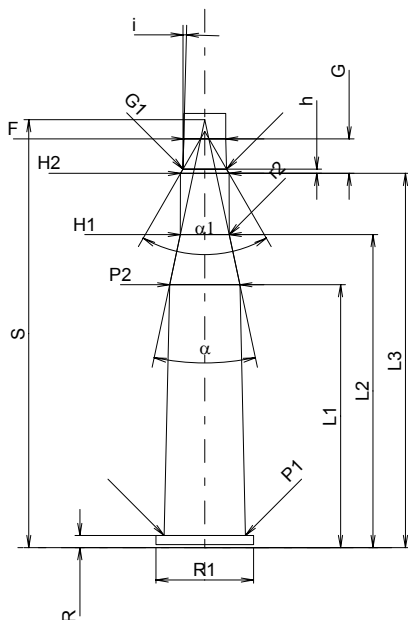
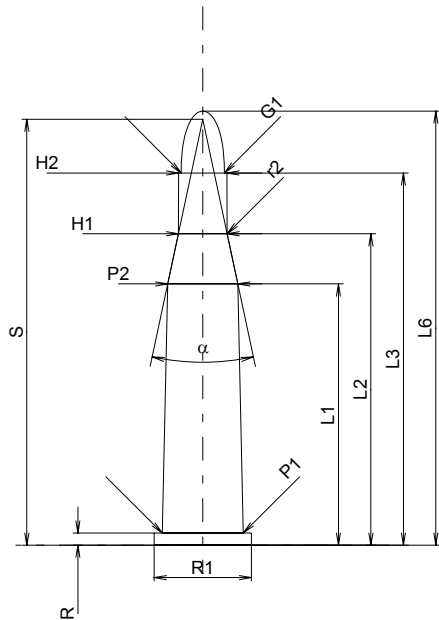

Échelle 1:1

Dimensions en << mm >>  
Dimensions et tolérances pour les canons  
d'épreuve: Voyez Annexe CR 1.

**CARTOUCHE MAXI****Longueurs**

L1	=	34.55
L2	=	41.18
L3 <sup>1)</sup>	=	49.22
L4	=	
L5	=	
L6	=	57.40

**Culot**

R <sup>1)</sup>	=	1.60	-0.25
R1	=	12.85	
R3	=		
E	=		
E1	=		
e min	=		
delta	=		
f	=		
beta	=		

**Chambre à poudre**

P1	=	10.72
P2*	=	9.26

**Cône de raccordement**

alpha*	=	24°
S*	=	56.33
r1 min	=	
r2	=	8.00

**Collet**

H1*	=	6.44
H2 <sup>1)</sup>	=	6.40

**Projectile**

G1 <sup>1)</sup>	=	5.70
G2	=	
F	=	
L3+G <sup>1)</sup>	=	53.80

**Pressions (Énergies)****Méthode transducteur**

Pmax	=	2850 bar
PK	=	3278 bar
PE	=	3560 bar
M	=	25.00
EE	=	1935 Joule

**Autres indications**

Fe <sup>1)</sup>	=	0.15
delta L	=	

**CHAMBRE MINI****Longueurs**

L1	=	34.76
L2	=	41.39
L3 <sup>1)</sup>	=	49.48

**Cuvette**

R <sup>1)</sup>	=	1.60
R1	=	12.88
R2	=	
R3	=	
r	=	

**Chambre à poudre**

E	=	
P1 <sup>1)</sup>	=	10.74
P2*	=	9.28

**Cône de raccordement**

alpha*	=	24°
S*	=	56.59
r1 max	=	
r2	=	8.00

**Collet**

H1*	=	6.46
H2 <sup>1)</sup>	=	6.43

**Prise de rayures**

G1 <sup>1)</sup> *	=	5.77
G <sup>1)</sup>	=	4.58
alpha1*	=	60°
h	=	0.57
s	=	
i <sup>1)</sup> *	=	1°30'
w	=	

**Canon**

F <sup>1)</sup> *	=	5.56
Z <sup>1)</sup>	=	5.69

**Rayures**

b	=	1.88
N	=	6
u	=	406.00
Q	=	25.03 mm <sup>2</sup>

Notes: 1) A' contrôler pour la sécurité  
\* Dimensions de base