

C.I.P.**366 TKM**

TAB. X

Date 16-05-18

Pays d'origine: RU

Révision 20-11-10

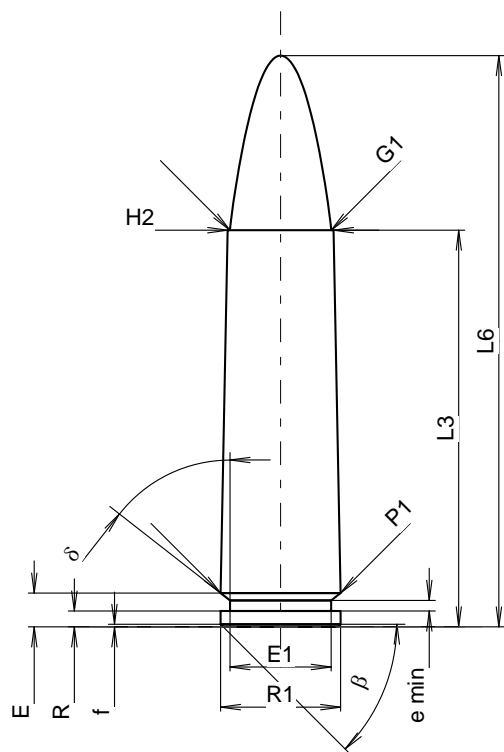
**CARTOUCHE MAXI****Longueurs**

L1	=		
L2	=		
L3 ¹⁾	=	37.50	-0.25
L4	=		
L5	=		
L6	=	54.00	

Culot

R	=	1.50	
R1	=	11.35	
R3	=		
E	=	3.20	
E1	=	9.56	
e min	=	1.00	
δ	=	51°58'12"	
f	=	0.25	
β	=	45°	

Chambre à poudre

P1	=	11.35	
P2	=		

Cône de raccordement

α	=		
S	=		
r1 min	=		
r2	=		

Collet

H1	=		
H2 ¹⁾	=	10.00	

Projectile

G1 ¹⁾	=	9.58	
G2	=		
F	=		
L3+G ¹⁾	=	42.50	

Pressions (Énergies)**Méthode transducteur**

Pmax	=	3300 bar	
PK	=	3795 bar	
PE	=	4290 bar	
M	=	25.00	

Autres indications

Fe ¹⁾⁶⁾	=	0.15	
delta L	=		

CHAMBRE MINI**Longueurs**

L1	=		
L2	=		
L3 ¹⁾	=	37.55	

Cuvette

R	=		
R1	=	11.38	
R2	=		
R3	=		
r	=		

Chambre à poudre

E	=	3.20	
P1 ¹⁾	=	11.37	
P2	=		

Cône de raccordement

α	=		
S	=		
r1 max	=		
r2	=		

Collet

H1	=		
H2 ¹⁾	=	10.02	

Prise de rayures

G1 ^{1)*}	=	9.65	
G ¹⁾	=	5.00	
α1	=	120°	
h*	=	0.11	
s	=		
i ^{1)*}	=	0°52'50"	
w	=		

Canon

F ^{1)*}	=	9.50	
Z	=	9.50	

Rayures

b	=		
N	=		
u	=		
Q	=	70.88	mm ²

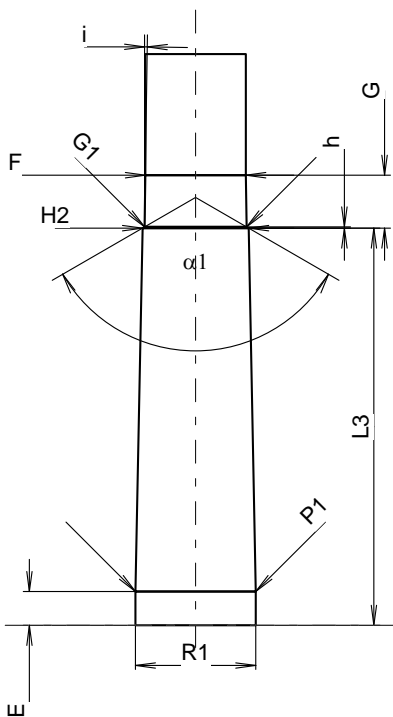

Échelle 1.4:1

Dimensions en << mm >>
Dimensions et tolérances pour les canons
d'épreuve: Voyez Annexe CR 1.

Notes: 1) A' contrôler pour la sécurité
6) Feuillure sur la bouche
* Dimensions de base