

C.I.P.**7 mm Rem. SA Ultra Mag.**

TAB.

I

Date

02-03-01

Pays d'origine: US

Révision

04-09-27

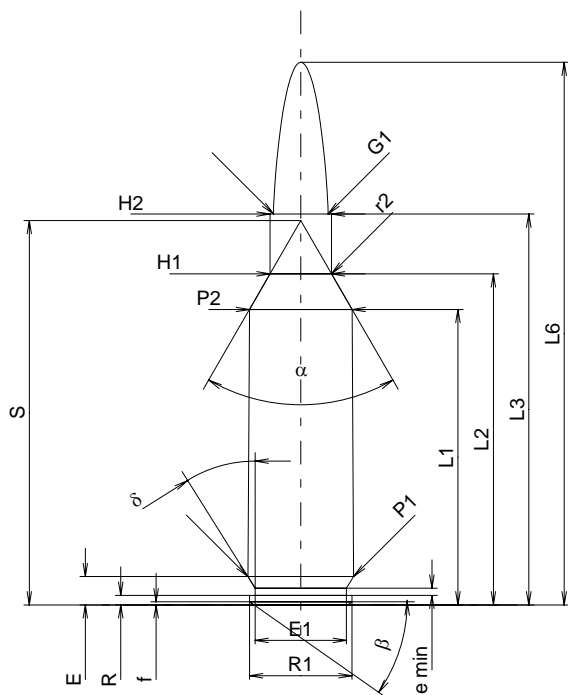
**CARTOUCHE MAXI****Longueurs**

L1 ¹⁾	=	39.07	-0.20
L2 ¹⁾	=	43.79	-0.20
L3 ¹⁾	=	51.69	
L4	=		
L5	=		
L6	=	71.76	

Culot

R	=	1.27	
R1	=	13.56	
R3	=		
E	=	3.75	
E1	=	12.07	
e min	=	0.94	
delta	=	32°	
f	=	0.41	
beta	=	35°	

Chambre à poudre

P1	=	14.00	
P2 ^{1)*}	=	13.58	-0.20

Cône de raccordement

alpha*	=	60°	
S*	=	50.83	
r1 min	=		
r2	=	3.18	

Collet

H1*	=	8.13	
H2 ¹⁾	=	8.13	

Projectile

G1 ¹⁾	=	7.23	
G2	=	7.04	
F	=		
L3+G ¹⁾	=	59.88	

Pressions (Énergies)**Méthode transducteur**

Pmax	=	4400 bar	
PK	=	5060 bar	
PE	=	5500 bar	
M	=	25.00	
EE	=	4500 Joule	

Autres indications

Fe	=	0.10	
delta L	=		

CHAMBRE MINI**Longueurs**

L1	=	38.95	
L2	=	43.65	
L3 ¹⁾	=	51.94	

Cuvette

R	=		
R1	=	14.05	
R2	=		
R3	=		
r	=		

Chambre à poudre

E	=	3.75	
P1 ¹⁾	=	14.01	
P2*	=	13.61	

Cône de raccordement

alpha ^{1)*}	=	60°	
S*	=	50.74	
r1 max	=		
r2	=	3.18	

Collet

H1*	=	8.18	
H2 ¹⁾	=	8.15	

Prise de rayures

G1 ^{1)*}	=	7.23	
G ¹⁾	=	8.19	
alpha1*	=	90°	
h	=	0.46	
s	=	2.75	
i ^{1)*}	=	1°	
w	=		

Canon

F ^{1)*}	=	7.04	
Z ¹⁾	=	7.21	

Rayures

b	=	2.79	
N	=	6	
u	=	254.00	
Q	=	40.39	mm ²

Échelle 1:1

Dimensions en << mm >>
Dimensions et tolérances pour les canons
d'épreuve: Voyez Annexe CR 1.

Notes: 1) A' contrôler pour la sécurité
* Dimensions de base