

C.I.P.**416 TYR**

TAB.

I

Date

14-05-22

Révision

Pays d'origine: TR

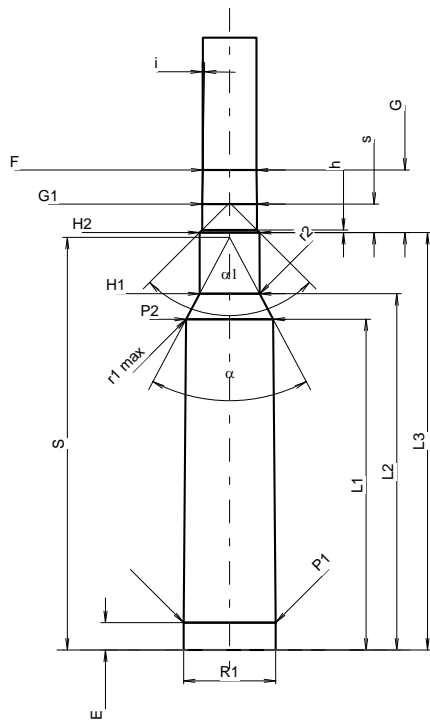
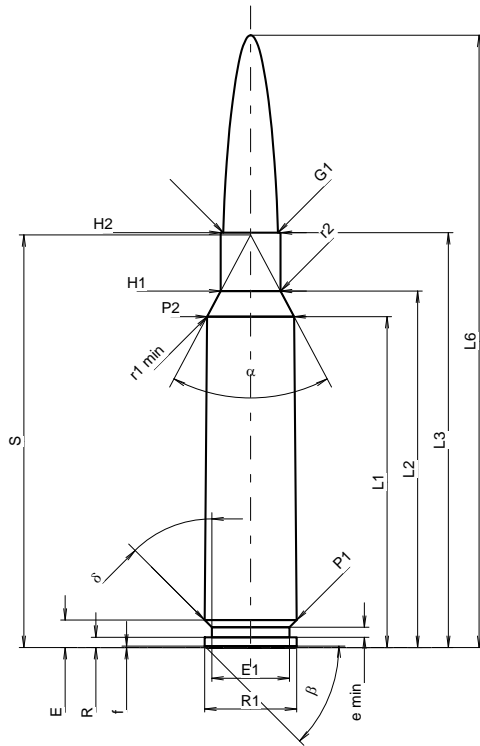

Échelle 1:1.46

Dimensions en << mm >>
Dimensions et tolérances pour les canons
d'épreuve: Voyez Annexe CR1.

CARTOUCHE MAXI**Longueurs**

L1 ¹⁾	=	64.06	-0.20
L2 ¹⁾	=	69.00	-0.20
L3 ¹⁾	=	80.30	
L4	=		
L5	=		
L6	=	118.50	

Culot

R	=	2.00	
R1	=	17.78	
R3	=		
E	=	5.31	
E1	=	15.00	
e min	=	1.92	
delta	=	45°	
f	=	0.30	
beta	=	45°	

Chambre à poudre

P1	=	17.78	
P2 ¹⁾ *	=	16.80	-0.20

Cône de raccordement

alpha *	=	56°	
S *	=	79.86	
r1 min	=	1.00	
r2	=	3.20	

Collet

H1 *	=	11.55	
H2 ¹⁾	=	11.55	

Projectile

G1 ¹⁾	=	10.57	
G2	=		
F	=		
L3+G ¹⁾	=	92.39	

Pressions (Énergies)**Méthode transducteur**

Pmax	=	4400 bar	
PK	=	5060 bar	
PE	=	5500 bar	
M	=	25.00	
EE	=	10500 Joule	

Autres indications

Fe ¹⁾³⁾	=	0.10	
delta L	=		

Notes: 1) A' contrôler pour la sécurité
3) Feuillure sur la cone de raccordement
* Dimensions de base

CHAMBRE MINI**Longueurs**

L1	=	64.03	
L2	=	68.95	
L3 ¹⁾	=	80.80	

Cuvette

R	=		
R1	=	17.83	
R2	=		
R3	=		
r	=		

Chambre à poudre

E	=	5.31	
P1 ¹⁾	=	17.81	
P2 *	=	16.83	

Cône de raccordement

alpha ¹⁾ *	=	56°	
S *	=	79.86	
r1 max	=	1.00	
r2	=	3.50	

Collet

H1 *	=	11.60	
H2 ¹⁾	=	11.58	

Prise de rayures

G1 ¹⁾ *	=	10.59	
G ¹⁾	=	12.09	
alpha l	=	90°	
h	=	0.50	
s *	=	5.50	
i ¹⁾ *	=	1°	
w	=		

Canon

F ¹⁾ *	=	10.36	
Z ¹⁾	=	10.57	

Rayures

b	=	3.25	
N	=	6	
u	=	330.20	
Q	=	86.38	mm ²