

C.I.P.**408 Chey Tac**

TAB.	I
Date	13-05-22
Révision	16-10-18

Pays d'origine: US

Marquage alternatif: 10,36 x 77 mm

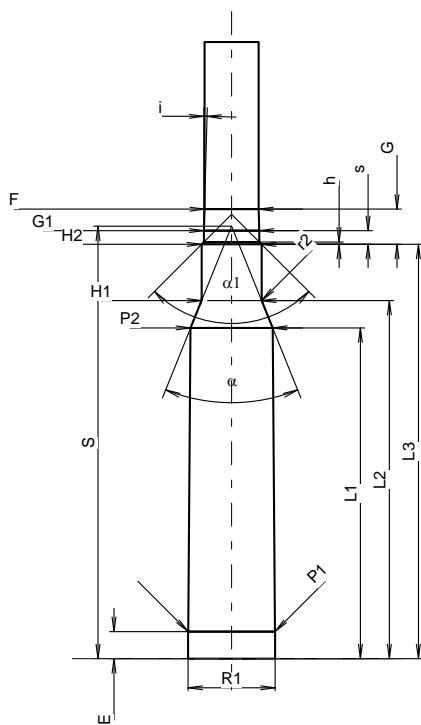
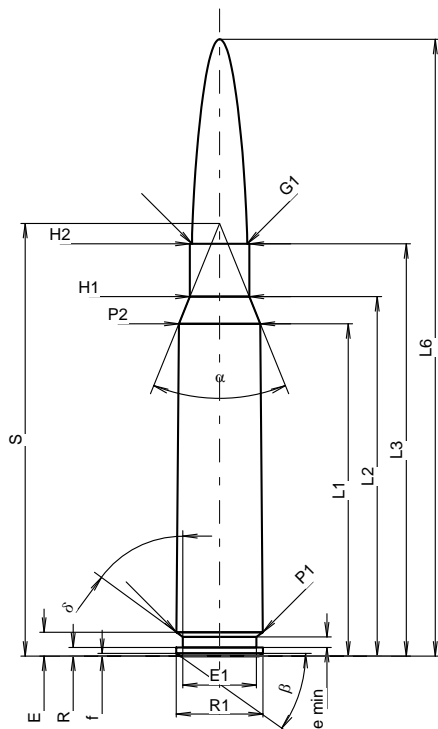

Échelle 1:1.42

Dimensions en << mm >>
Dimensions et tolérances pour les canons
d'épreuve: Voyez Annexe CR1.

CARTOUCHE MAXI**Longueurs**

L1 ¹⁾	=	62.23	-0.20
L2 ¹⁾	=	67.31	-0.20
L3 ¹⁾	=	77.21	
L4	=		
L5	=		
L6	=	115.50	

Culot

R	=	1.60	
R1	=	16.25	
R3	=		
E	=	4.47	
E1	=	13.80	
e min	=	2.00	
delta	=	53°44'	
f	=	0.50	
beta	=	35°19'59"	

Chambre à poudre

P1	=	16.18	
P2 ¹⁾ *	=	15.24	-0.20

Cône de raccordement

alpha *	=	44°08'46"	
S *	=	81.02	
r1 min	=		
r2	=		

Collet

H1 *	=	11.12	
H2 ¹⁾	=	11.12	

Projectile

G1 ¹⁾	=	10.36	
G2	=		
F	=	10.16	
L3+G ¹⁾	=	83.80	

Pressions (Énergies)**Méthode transducteur**

Pmax	=	4400 bar	
PK	=	5060 bar	
PE	=	5500 bar	
M	=	25.00	
EE	=	10500 Joule	

Autres indications

Fe ¹⁾³⁾	=	0.10	
delta L	=	0.12	

CHAMBRE MINI**Longueurs**

L1	=	61.96	
L2	=	67.08	
L3 ¹⁾	=	77.60	

Cuvette

R	=		
R1	=	16.30	
R2	=		
R3	=		
r	=		

Chambre à poudre

E	=	5.08	
P1 ¹⁾	=	16.23	
P2 *	=	15.36	

Cône de raccordement

alpha ¹⁾ *	=	43°55'49"	
S *	=	81.00	
r1 max	=		
r2	=	3.05	

Collet

H1 *	=	11.23	
H2 ¹⁾	=	11.23	

Prise de rayures

G1 ¹⁾ *	=	10.37	
G ¹⁾	=	6.59	
alpha1	=	90°	
h	=	0.43	
s *	=	2.58	
i ¹⁾ *	=	1°30'	
w	=		

Canon

F ¹⁾ *	=	10.16	
Z ¹⁾ *	=	10.36	

Rayures

b	=	2.57	
N	=	8	
u	=	330.20	
Q	=	83.15	mm ²

Notes: 1) A' contrôler pour la sécurité
3) Feuillure sur la cone de raccordement
* Dimensions de base