

**C.I.P.****404 Riml. N.E.**

TAB.

I

Date

84-06-14

Révision

20-04-21

Pays d'origine: GB

Marquage alternatif: 404 Jeffery

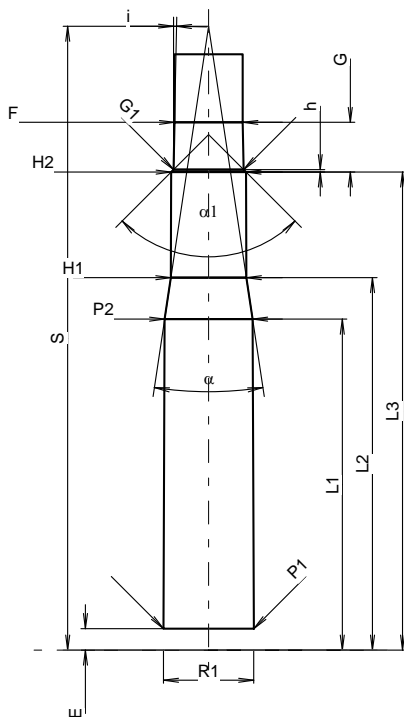
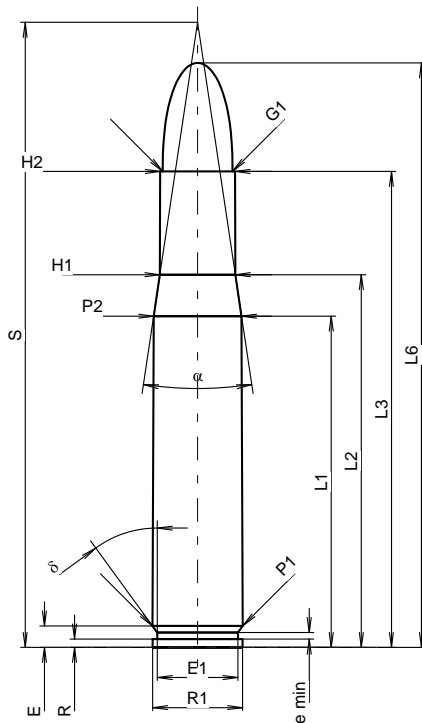

Échelle 1:1.16

Dimensions en << mm >>  
Dimensions et tolérances pour les canons  
d'épreuve: Voyez Annexe CR 1.

**CARTOUCHE MAXI****Longueurs**

L1 <sup>1)</sup> *	=	50.82	-0.20
L2 <sup>1)</sup> *	=	57.18	-0.20
L3 <sup>1)</sup>	=	73.02	
L4	=		
L5	=		
L6	=	89.66	

**Culot**

R	=	1.27	
R1	=	13.79	
R3	=		
E	=	3.30	
E1	=	12.37	
e min	=	1.02	
delta	=	36°02'39"	
f	=		
beta	=		

**Chambre à poudre**

P1	=	13.84	
P2 <sup>1)</sup> *	=	13.46	-0.20

**Cône de raccordement**

alpha	=	16°59'26"	
S	=	95.88	
r1 min	=		
r2	=		

**Collet**

H1 *	=	11.56	
H2 <sup>1)</sup>	=	11.48	

**Projectile**

G1 <sup>1)</sup>	=	10.72	
G2	=		
F	=		
L3+G <sup>1)</sup>	=	80.64	

**Pressions (Énergies)****Méthode transducteur**

Pmax	=	3650 bar	
PK	=	4198 bar	
PE	=	4560 bar	
M	=	25.00	
EE	=	6815 Joule	

**Autres indications**

Fe <sup>1)</sup>	=	0.15	
delta L	=		

**CHAMBRE MINI****Longueurs**

L1 *	=	50.77	
L2 *	=	57.13	
L3 <sup>1)</sup>	=	73.33	

**Cuvette**

R	=	1.27	
R1	=	13.84	
R2	=		
R3	=		
r	=		

**Chambre à poudre**

E	=	3.30	
P1 <sup>1)</sup>	=	13.87	
P2 *	=	13.49	

**Cône de raccordement**

alpha <sup>1)</sup>	=	17°04'45"	
S	=	95.69	
r1 max	=		
r2	=		

**Collet**

H1 *	=	11.58	
H2 <sup>1)</sup>	=	11.51	

**Prise de rayures**

G1 <sup>1)</sup> *	=	10.77	
G <sup>1)</sup> *	=	7.62	
alpha1	=	90°	
h *	=	0.37	
s	=		
i <sup>1)</sup>	=	1°13'28"	
w	=		

**Canon**

F <sup>1)</sup> *	=	10.46	
Z <sup>1)</sup>	=	10.77	

**Rayures**

b	=	3.50	
N	=	6	
u	=	420.00	
Q	=	89.25	mm <sup>2</sup>

Notes: 1) A' contrôler pour la sécurité  
\* Dimensions de base