

C.I.P.**375 Rem. Ultra Mag.**

TAB. I

Date 02-01-22

Révision 07-06-20

Pays d'origine: US

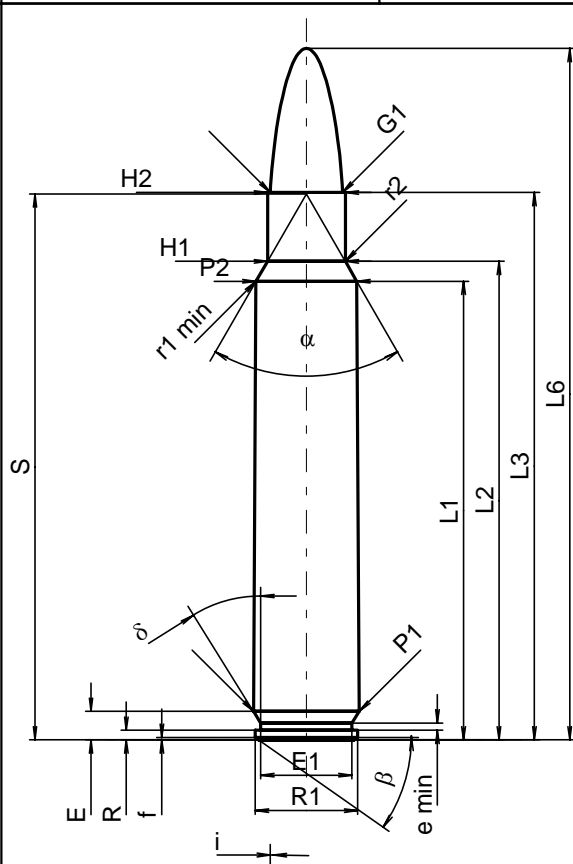
**CARTOUCHE MAXI****Longueurs**

L1 ¹⁾	=	60.64	-0.20
L2 ¹⁾	=	63.28	-0.20
L3 ¹⁾	=	72.39	
L4	=		
L5	=		
L6	=	91.44	

Culot

R	=	1.27	
R1	=	13.56	
R3	=		
E	=	3.75	
E1	=	12.07	
e min	=	0.94	
delta	=	32°	
f	=	0.31	
beta	=	35°	

Chambre à poudre

P1	=	13.99	
P2 ^{1)*}	=	13.33	-0.20

Cône de raccordement

alpha*	=	60°	
S*	=	72.18	
r1 min	=	0.76	
r2	=	3.18	

Collet

H1*	=	10.29	
H2 ¹⁾	=	10.29	

Projectile

G1 ¹⁾	=	9.55	
G2	=		
F	=		
L3+G ¹⁾	=	84.38	

Pressions (Énergies)**Méthode transducteur**

Pmax	=	4400 bar	
PK	=	5060 bar	
PE	=	5500 bar	
M	=	25.00	
EE	=	7350 Joule	

Autres indications

Fe ¹⁾	=	0.10	
delta L	=	0.10	

CHAMBRE MINI**Longueurs**

L1	=	60.51	
L2	=	63.13	
L3 ¹⁾	=	72.64	

Cuvette

R	=		
R1	=	14.05	
R2	=		
R3	=		
r	=		

Chambre à poudre

E	=	3.75	
P1 ¹⁾	=	14.02	
P2*	=	13.36	

Cône de raccordement

alpha ^{1)*}	=	60°	
S*	=	72.08	
r1 max	=	0.76	
r2	=	3.18	

Collet

H1*	=	10.34	
H2 ¹⁾	=	10.31	

Prise de rayures

G1 ^{1)*}	=	9.55	
G ¹⁾	=	11.99	
alpha1	=	90°	
h	=	0.38	
s*	=	4.83	
i ^{1)*}	=	1°	
w	=		

Canon

F ^{1)*}	=	9.30	
Z ¹⁾	=	9.55	

Rayures

b	=	2.92	
N	=	6	
u	=	304.80	
Q	=	70.16	mm ²

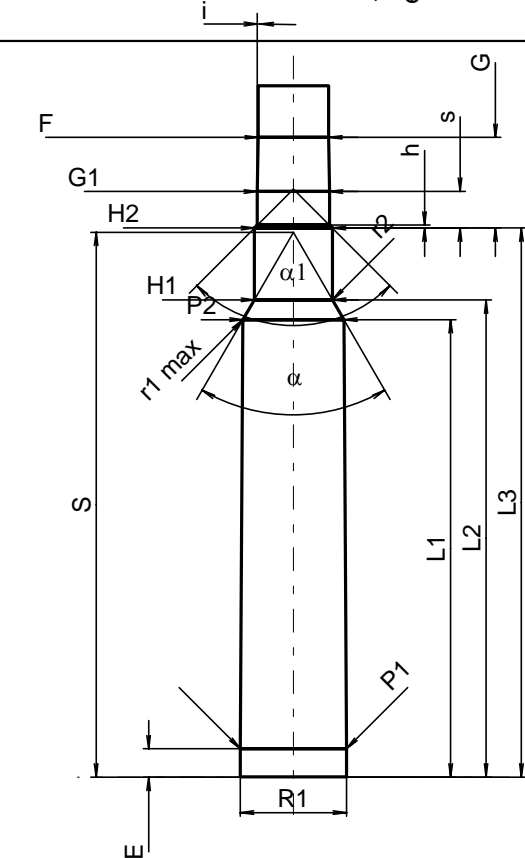

Échelle 1:1

Dimensions en << mm >>
Dimensions et tolérances pour les canons
d'épreuve: Voyez Annexe CR 1.

Notes: 1) A contrôler pour la sécurité
* Dimensions de base