

C.I.P.

300 Win. Short Mag.

TAB.	I
Date	02-01-22
Révision	08-09-23

Pays d'origine: US

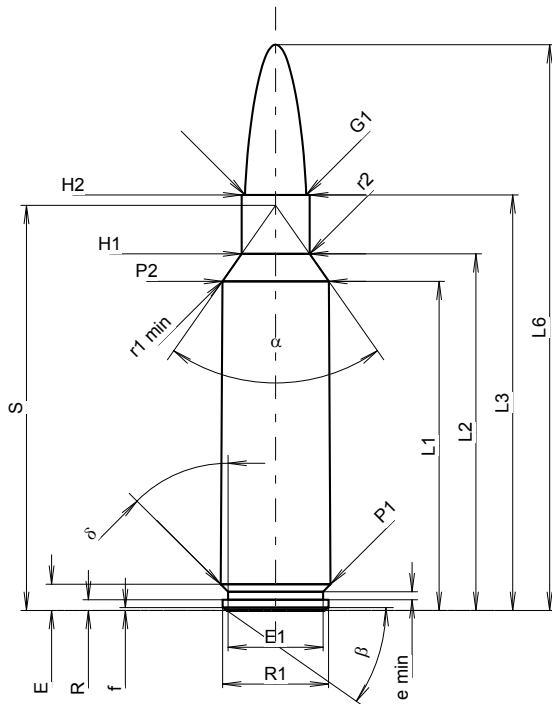

CARTOUCHE MAXI

Longueurs

L1 ¹⁾	=	42.25	-0.20
L2 ¹⁾	=	45.77	-0.20
L3 ¹⁾	=	53.34	
L4	=		
L5	=		
L6	=	72.64	

Culot

R	=	1.37	
R1	=	13.59	
R3	=		
E	=	3.35	
E1	=	12.19	
e min	=	1.02	
delta	=	45°	
f	=	0.36	
beta	=	35°	

Chambre à poudre

P1	=	14.12	
P2 ¹⁾ *	=	13.67	-0.20

Cône de raccordement

alpha [*]	=	70°	
S [*]	=	52.01	
r1 min	=	1.27	
r2	=	2.54	

Collet

H1 [*]	=	8.74	
H2 ¹⁾	=	8.74	

Projectile

G1 ¹⁾	=	7.85	
G2	=		
F	=		
L3+G ¹⁾	=	58.56	

Pressions (Énergies)

Méthode transducteur

Pmax	=	4400 bar	
PK	=	5060 bar	
PE	=	5500 bar	
M	=	25.00	
EE	=	5250 Joule	

Autres indications

Fe ¹⁾³⁾	=	0.10	
delta L	=	0.10	

CHAMBRE MINI

Longueurs

L1	=	42.13	
L2	=	45.63	
L3 ¹⁾	=	53.59	

Cuvette

R	=		
R1	=	14.19	
R2	=		
R3	=		
r	=		

Chambre à poudre

E	=	3.35	
P1 ¹⁾	=	14.15	
P2 [*]	=	13.70	

Cône de raccordement

alpha ^{1)*)}	=	70°	
S [*]	=	51.91	
r1 max	=	1.27	
r2	=	3.05	

Collet

H1 [*]	=	8.79	
H2 ¹⁾	=	8.76	

Prise de rayures

G1 ^{1)*)}	=	7.87	
G ¹⁾	=	5.22	
alpha1 [*]	=	90°	
h	=	0.45	
s	=		
i ^{1)*)}	=	1°30'	
w	=		

Canon

F ^{1)*)}	=	7.62	
Z ¹⁾	=	7.82	

Rayures

b	=	4.49	
N	=	4	
u	=	254.00	
Q	=	47.52	mm ²

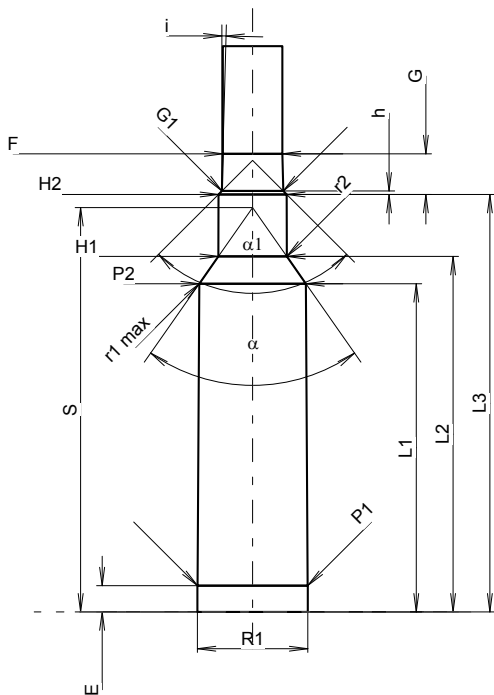

Échelle 1.03:1

Dimensions en << mm >>
Dimensions et tolérances pour les canons
d'épreuve: Voyez Annexe CR 1.

Notes: 1) A' contrôler pour la sécurité
3) Feuillure sur la cone de raccordement
* Dimensions de base