

**C.I.P.****243 Win. Super Short Mag.**

TAB. I

Date 03-11-07

Révision 08-09-23

Pays d'origine: US

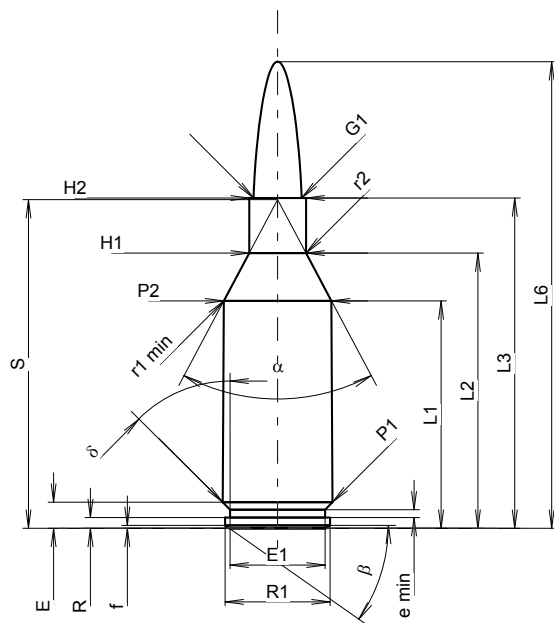
**CARTOUCHE MAXI****Longueurs**

L1 <sup>1)</sup>	=	29.21	-0.20
L2 <sup>1)</sup>	=	35.35	-0.20
L3 <sup>1)</sup>	=	42.42	
L4	=		
L5	=		
L6	=	59.94	

**Culot**

R	=	1.37	
R1	=	13.49	
R3	=		
E	=	3.35	
E1	=	12.19	
e min	=	1.02	
delta	=	45°	
f	=	0.36	
beta	=	35°	

**Chambre à poudre**

P1	=	14.12	
P2 <sup>1)</sup> *	=	13.82	-0.20

**Cône de raccordement**

alpha *	=	56°	
S *	=	42.21	
r1 min	=	1.27	
r2	=	3.30	

**Collet**

H1 *	=	7.29	
H2 <sup>1)</sup>	=	7.29	

**Projectile**

G1 <sup>1)</sup>	=	6.17	
G2	=		
F	=		
L3+G <sup>1)</sup>	=	47.16	

**Pressions (Énergies)****Méthode transducteur**

Pmax	=	4400 bar	
PK	=	5060 bar	
PE	=	5500 bar	
M	=	25.00	
EE	=	3150 Joule	

**Autres indications**

Fe <sup>3)</sup>	=	0.10	
delta L	=	0.08	

**CHAMBRE MINI****Longueurs**

L1	=	29.11	
L2	=	35.25	
L3 <sup>1)</sup>	=	42.67	

**Cuvette**

R	=		
R1	=	14.20	
R2	=		
R3	=		
r	=		

**Chambre à poudre**

E	=	3.35	
P1 <sup>1)</sup>	=	14.15	
P2 *	=	13.87	

**Cône de raccordement**

alpha <sup>1)</sup> *	=	56°	
S *	=	42.15	
r1 max	=	1.27	
r2	=	4.06	

**Collet**

H1 *	=	7.34	
H2 <sup>1)</sup>	=	7.32	

**Prise de rayures**

G1 <sup>1)</sup> *	=	6.24	
G <sup>1)</sup>	=	4.74	
alpha 1 *	=	90°	
h	=	0.54	
s	=		
i <sup>1)</sup> *	=	1°30'	
w	=		

**Canon**

F <sup>1)</sup> *	=	6.02	
Z <sup>1)</sup>	=	6.17	

**Rayures**

b	=	2.54	
N	=	4	
u	=	254.00	
Q	=	29.25	mm <sup>2</sup>

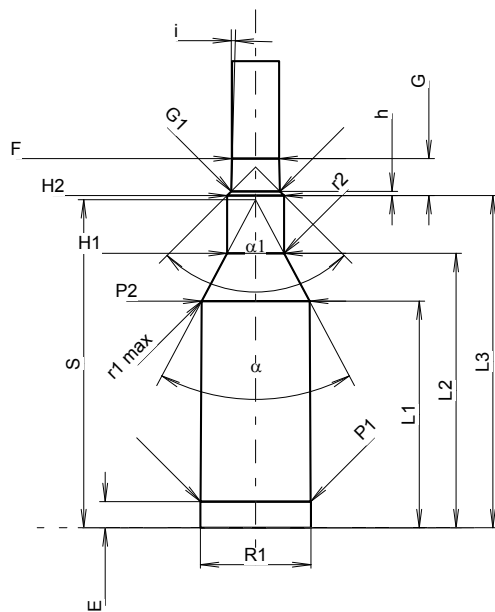

Échelle 1.03:1

Dimensions en << mm >>  
Dimensions et tolérances pour les canons  
d'épreuve: Voyez Annexe CR 1.

Notes: 1) A' contrôler pour la sécurité  
3) Feuillure sur la cone de raccordement  
\* Dimensions de base