

C.I.P.**22 PPC-USA**

TAB. I

Date 89-04-18

Pays d'origine: FI

Révision 02-05-15

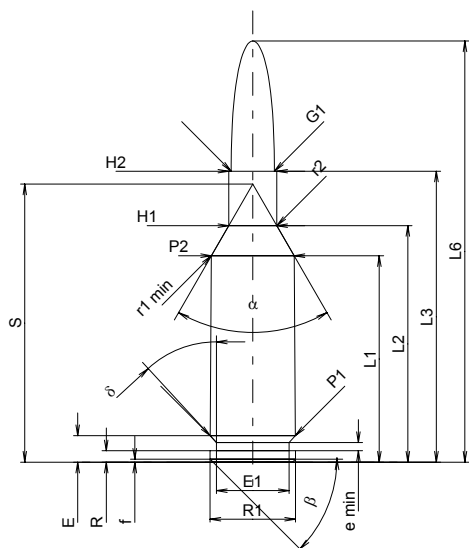
**CARTOUCHE MAXI****Longueurs**

L1 ¹⁾	=	27.30	-0.20
L2 ¹⁾	=	31.28	-0.20
L3 ¹⁾	=	38.48	
L4	=		
L5	=		
L6	=	55.70	

Culot

R	=	1.50	
R1	=	11.30	
R3	=		
E	=	3.50	
E1	=	9.60	
e min	=	1.10	
delta	=	42°40'48"	
f	=	0.40	
beta	=	45°	

Chambre à poudre

P1	=	11.26	
P2 ¹⁾ *	=	10.95	-0.20

Cône de raccordement

alpha	=	60°02'47"	
S	=	36.77	
r1 min	=	1.00	
r2	=	3.00	

Collet

H1*	=	6.35	
H2 ¹⁾	=	6.35	

Projectile

G1 ¹⁾	=	5.70	
G2	=		
F	=		
L3+G ¹⁾	=	43.96	

Pressions (Énergies)**Méthode transducteur**

Pmax	=	4050 bar	
PK	=	4658 bar	
PE	=	5060 bar	
M	=	17.50	
EE	=	1935 Joule	

Autres indications

Fe ¹⁾	=	0.10	
delta L	=		

CHAMBRE MINI**Longueurs**

L1*	=	27.27	
L2*	=	31.25	
L3 ¹⁾	=	38.74	

Cuvette

R	=	1.50	
R1	=	11.32	
R2	=		
R3	=		
r	=		

Chambre à poudre

E	=	3.50	
P1 ¹⁾	=	11.28	
P2*	=	10.98	

Cône de raccordement

alpha ¹⁾	=	59°56'16"	
S	=	36.79	
r1 max	=	0.50	
r2	=	3.00	

Collet

H1*	=	6.39	
H2 ¹⁾	=	6.38	

Prise de rayures

G1 ¹⁾ *	=	5.72	
G ¹⁾ *	=	5.48	
alpha1	=	90°	
h	=	0.33	
s*	=	1.85	
i ¹⁾	=	1°30'	
w	=		

Canon

F ¹⁾ *	=	5.53	
Z ¹⁾	=	5.66	

Rayures

b	=	2.04	
N	=	6	
u	=	355.00	
Q	=	24.83	mm ²

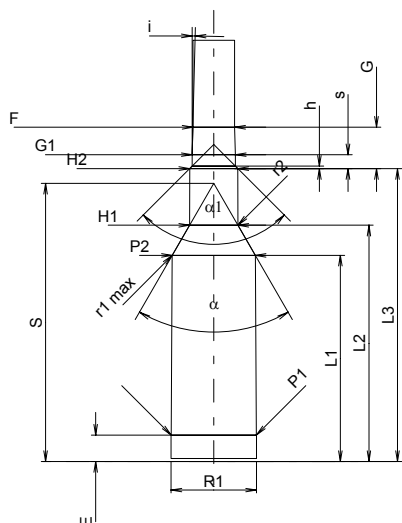

Échelle 1:1

Dimensions en << mm >>
Dimensions et tolérances pour les canons
d'épreuve: Voyez Annexe CR 1.

Notes: 1) A' contrôler pour la sécurité
* Dimensions de base