

**C.I.P.****12,7 x 108**

TAB. I

Date 17-05-17

Pays d'origine: RU

Révision

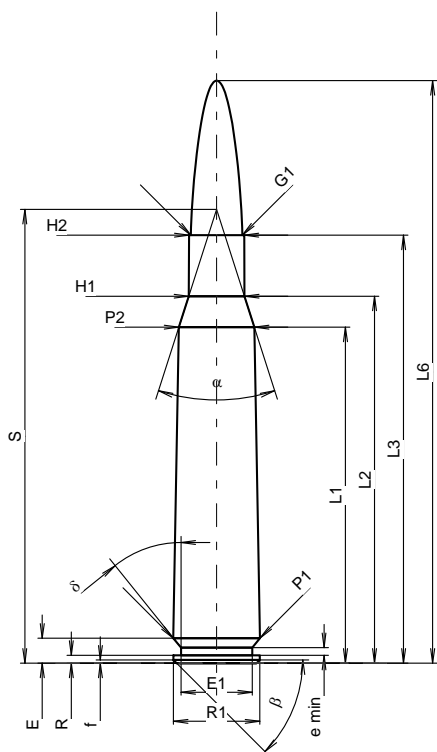
**CARTOUCHE MAXI****Longueurs**

L1 <sup>1)</sup>	=	84.80	-0.20
L2 <sup>1)</sup>	=	92.60	-0.20
L3 <sup>1)</sup>	=	108.00	
L4	=		
L5	=		
L6	=	147.00	

**Culot**

R	=	2.00	
R1	=	21.80	
R3	=		
E	=	6.30	
E1	=	18.00	
e min	=	1.90	
δ	=	38°44'	
f	=	0.80	
β	=	45°	

**Chambre à poudre**

P1	=	21.85	
P2 <sup>1)</sup> *	=	19.05	-0.20

**Cône de raccordement**

α <sup>*</sup>	=	35°32'34"	
S <sup>*</sup>	=	114.52	
r1 min	=		
r2	=		

**Collet**

H1 <sup>*</sup>	=	14.05	
H2 <sup>1)</sup>	=	13.90	

**Projectile**

G1 <sup>1)</sup>	=	13.01	
G2	=		
F	=		
L3+G <sup>1)</sup>	=	138.00	

**Pressions (Énergies)****Méthode transducteur**

Pmax	=	3050 bar	
PK	=	3508 bar	
PE	=	3813 bar	
M	=	25.00	
EE	=	19200 Joule	

**Autres indications**

Fe <sup>1)3)</sup>	=	0.15	
delta L	=	0.57	

**CHAMBRE MINI****Longueurs**

L1	=	83.95	
L2	=	91.95	
L3 <sup>1)</sup>	=	108.70	

**Cuvette**

R	=		
R1	=	22.00	
R2	=		
R3	=		
r	=		

**Chambre à poudre**

E	=	5.70	
P1 <sup>1)</sup>	=	21.89	
P2 <sup>*</sup>	=	19.23	

**Cône de raccordement**

α <sup>1)</sup> *	=	35°17'40"	
S <sup>*</sup>	=	114.17	
r1 max	=		
r2	=		

**Collet**

H1 <sup>*</sup>	=	14.14	
H2 <sup>1)</sup>	=	13.91	

**Prise de rayures**

G1 <sup>1)</sup> *	=	13.00	
G <sup>1)</sup>	=	30.00	
α1	=	5°12'37"	
h <sup>*</sup>	=	10.00	
s	=		
i <sup>1)</sup> *	=	0°29'13"	
w	=		

**Canon**

F <sup>1)</sup> *	=	12.66	
Z <sup>1)</sup>	=	13.00	

**Rayures**

b	=	2.80	
N	=	8	
u	=	380.00	
Q	=	129.72	mm <sup>2</sup>

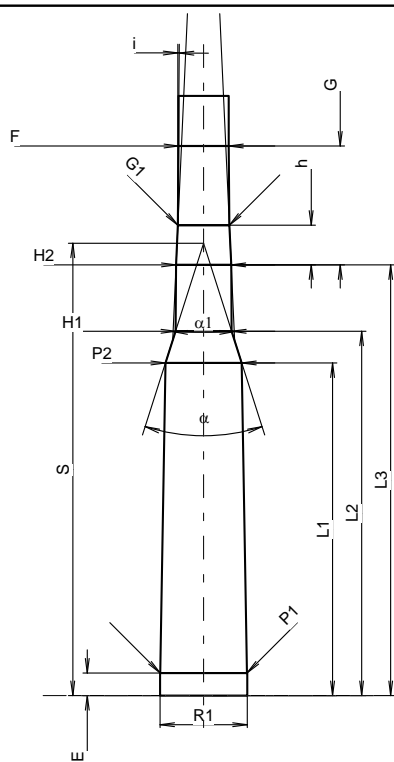

Échelle 1:1.91

Dimensions en << mm >>  
Dimensions et tolérances pour les canons  
d'épreuve: Voyez Annexe CR 1.

Notes: 1) A' contrôler pour la sécurité  
3) Feuillure sur la cone de raccordement  
\* Dimensions de base